

AQUAFORCE®

30XW/30XW-P 30XWH/30XWHP

Water-Cooled Screw
Chillers
Water-sourced screw heat
pumps

Nominal cooling capacity:
269-1736 kW

Nominal heating capacity:
317-2019 kW



CARRIER participates in the ECP programme for
LCP-HP Check ongoing validity of certificate:
www.eurovent-certification.com

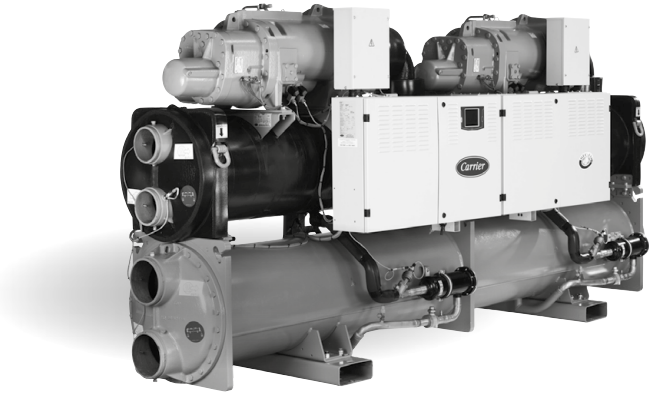

Low energy consumption
High reliability
Easy and fast installation
Low operating sound levels
Environmental care

The 30XW liquid chillers are the premium solution for industrial and commercial applications where installers, consultants and building owners require optimal performances and maximum quality.

The 30XW liquid chillers are designed to meet current and future requirements in terms of energy efficiency, flexibility of use and compactness. They use the most reliable technologies available today:

- Twin-rotor screw compressors with a variable capacity valve.
- Refrigerant R134a.
- Flooded heat exchangers that are mechanically cleanable.
- Carrier SmartVu™ control with color touch screen user interface that includes 10 languages.

To meet to all environmental and economic requirements, the 30XW is available in two efficiency classes:

- Entry-level efficiency 30XW units that offer an optimised balance of technical and economical aspects;
- Premium-efficiency 30XW-P units that offer unequalled energy efficiency to satisfy the most stringent demands of building owners wanting to reduce operating costs to the minimum.

The 30XW AquaForce range is also split into two versions:

- 30XW for air conditioning and refrigeration applications.
- 30XWH for heating applications.

As standard, the unit can provide an evaporator leaving temperature down to 3,3°C (-12°C optional), and when operating as a heat pump, it can deliver up to 50°C (63°C optional) on the condenser side.



Customer Benefits

Low energy consumption

- SEPR up to 9,1 and SEER up to 7,7.
- The high energy efficiency is reached through.
- Twin-rotor screw compressor equipped with a high-efficiency motor and a variable capacity valve that permits exact matching of the cooling capacity to the load.
- Flooded multi-pipe heat exchangers for increased heat exchange efficiency.
- Electronic expansion device permitting operation at a lower condensing pressure and improved utilisation of the evaporator heat exchange surface.
- Economizer system with electronic expansion device for increased cooling capacity (30XW-P).

Low operating sound levels

- Standard unit features include:
 - Silencers on the compressors discharge line.
 - Silencers on the economiser return line.
 - Acoustic insulation on the components that are most subjected to radiated noise.
 - Option 257 further reduces the global unit sound level.

Easy and fast installation

- Compact design:
 - The 30XW units are designed to offer the most compact dimensions on the market.
 - With a width of approximately 1 m up to 1600 kW the units can pass through standard door openings and only require minimum floor space in the plant room.

Compact, accessible unit - side view - sizes up to 1600 KW

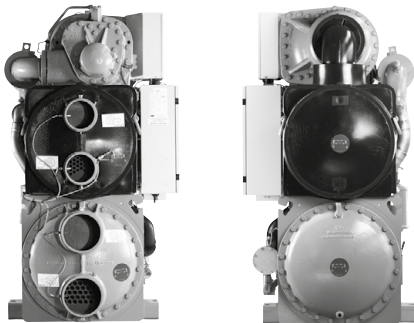

- Simplified electrical connections:
 - Main disconnect switch with high trip capacity.
 - Transformer to supply the integrated control circuit (400/24 V).
- Simplified hydraulic connections:
 - Victaulic connections on the evaporator and condenser.
 - Practical reference marks for entering and leaving water connections.
 - Possibility to reverse the heat exchanger water inlet and outlet at the factory.
 - Possibility to modify the number of heat exchanger passes.
- Fast commissioning:
 - Systematic factory operation test before shipment.
 - Quick-test function for step-by-step verification of the instruments, expansion devices and compressors.

Environmental care

- R-134a refrigerant:
 - HFC refrigerant with zero ozone depletion potential.
- Leak-tight refrigerant circuit:
 - Reduction of leaks as no capillary tubes and flare connections are used.
 - Verification of pressure transducers and temperature sensors without transferring refrigerant charge.
 - Discharge line shut-off valve and liquid line service valve for simplified maintenance.

High reliability and easy servicing

- The 30XW units offer increased global performance as well as Carrier's acclaimed product quality and reliability:
- Major components are selected and tested to minimize failures possibility, as well as many design choices have been taken in this perspective.
- Screw compressors:
 - Industrial-type screw compressors with oversized bearings and motor cooled by suction gas.
 - All compressor components are easily accessible on site minimising down-time.
- Refrigerant circuit:
 - Two independent refrigerant circuits (from 1000 kW upwards); the second one automatically takes over, if the first one develops a fault, maintaining partial cooling under all circumstances.
- Evaporator:
 - Electronic paddle-free flow switch. Auto-setting according to cooler size and fluid type.
- Auto-adaptive control:
 - Control algorithm prevents excessive compressor cycling (Carrier patent).
 - Automatic compressor unloading in case of abnormally high condensing pressure.
- Exceptional endurance tests:
 - Partnerships with specialised laboratories and use of limit simulation tools (finite element calculation) for the design of critical components.
 - Transport simulation test in the laboratory on a vibrating table and then on an endurance circuit (based on a military standard).

Technical insights

SmartVu™

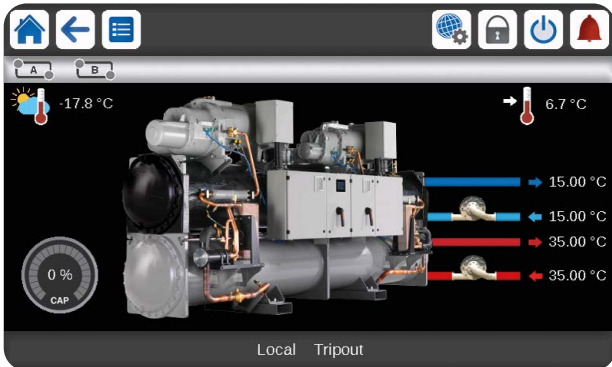

- New innovative smart control features :
 - An intuitive and user-friendly, coloured, 4.3" interface.
 - 1 languages available on choice: DE, EN, ES, FR, T, NL, PT, TR, TU + one additional customer choice.
 - Screen-shots with concise and clear information in local languages.
 - Complete menu, customised for different users (end user, service personnel and Carrier-factory technicians).
 - Setpoint offset based on the outside air temperature.
 - Safe operation and unit setting: Password protection ensures that unauthorised people cannot modify any advanced parameters.
 - Simple and "smart" intelligence uses data collection from the constant monitoring of all machine parameters to optimise unit operation.
 - Night-mode: Cooling capacity management for reduced noise level.
 - With hydraulic module: Water pressure display and water flow rate calculation.
- Energy management :
 - Internal time schedule clock controls chiller on/off times and operation at a second set-point.
 - The DCT (Data Collection Tool) records the alarms history to simplify and facilitate service operations.
- Maintenance functions :
 - F-Gas regulation leak check reminder alert.
 - Maintenance alert can be configured to days, months or hours of operation.
- Advanced communication features :
 - Easy and high-speed communication technology over Ethernet (IP) to a centralised building management system.
 - Access to multiple unit parameters.

Remote Management (Standard)

- Units with SmartVu™ control can be easily accessed from the internet, using a PC with an Ethernet connection. This makes remote control quick and easy and offers significant advantages for service operations.
- AquaForce with Greenspeed® Intelligence is equipped with an RS485 serial port that offers multiple remote control, monitoring and diagnostic possibilities. When networked with other Carrier equipment through the CCN (Carrier Comfort Network - proprietary protocol), all components form a HVAC system fully-integrated and balanced through one of the Carrier's network system products, like the Chiller System anager or the Plant System anager (optional).
- The 30XW/P'also communicates with other building management systems via optional communication gateways (BACnet, LON or JBus).
- The following commands/visualisations are possible from remote connection:
 - Start/Stop of the machine.
 - Dual set-point management: Through a dedicated contact is possible to activate a second set-point (example, unoccupied mode).
 - Demand limit setting: To limit the maximum chiller capacity to a predefined value.
 - Water pump control: These outputs control the contactors of one/two evaporator water pumps.
 - Water pumps changeover (only with hydraulic module options): These contacts are used to detect a water pump operation fault and automatically change over to the other pump.
 - Operation visualisation: indication if the unit is operating or if it is in stand-by (no cooling load).
 - Alarm visualisation.

Technical insights

Remote management (EMM option)

- The Energy Management Module offers extended remote control possibilities:
 - Room temperature: Permits set-point reset based on the building indoor air temperature (if Carrier thermostats are installed).
 - Set-point reset: Allows reset of the cooling set-point based on a 4-20 mA or 0-10 V signal.
 - Demand limit: Permits limitation of the maximum chiller capacity based on 0-10 V signal.
 - Demand limit 1 and 2: Closing of these contacts limits the maximum chiller capacity to two predefined values.
 - User safety: This contact can be used for any customer safety loop; opening the contact generates a specific alarm.
 - Ice storage end: When ice storage has finished, this input permits return to the second set-point (unoccupied mode).
 - Time schedule override: Closing of this contact cancels the programmed time schedule.
 - Out of service: This signal indicates that the chiller is completely out of service.
 - Chiller capacity: This analogue output (-1 gives an immediate indication of the chiller capacity).
 - Alert indication: This volt-free contact indicates the necessity to carry out a maintenance operation or the presence of a minor fault.
 - Compressors running status: Set of outputs (as many as the compressors number) indicating which compressors are running.

06T screw compressor

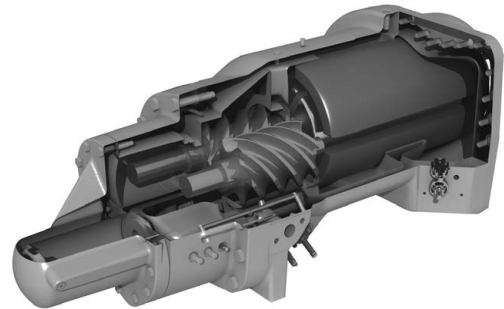

The new generation of the Carrier 06T screw compressors benefits from Carrier's long experience in the development of twin-rotor screw compressors. The compressor is equipped with bearings with oversized rollers, oil pressure lubricated for reliable and durable operation, even at maximum load.

A variable control valve controlled by the oil pressure permits infinitely variable cooling capacity. This system allows optimal adjustment of the compressor cooling capacity and ensures exceptionally high stability of the chilled water leaving temperature.

Among the other advantages: if a fault occurs e.g. if the condenser is fouled or at very high water temperature, the compressor does not switch off, but continues operation with a reduced capacity (unloaded mode).

The silencer in the discharge line considerably reduces discharge gas pulsations for much quieter operation.

The condenser includes an oil separator that minimises the amount of oil in circulation in the refrigerant circuit and re-directs it to the compressor function.

Digit number

1	2	3	4	5	6	7	8	9	1	1	1	1	1	1	1	1	1
3	0	X	W	-	-	0	2	5	4	B	0	0	0	1	-		

Legend:

- Digit 1 to 4 : Water-cooled chiller with screw compressor
- Digit 5 : Application type, - = Cooling, H = Heating
- Digit 6 : Efficiency, - = standard, P = premium
- Digit 7 to 10 : Model number based on cooling capacity in kW
- Digit 11 : Index for major product modification (visible impact for customer)
- Digit 12 to 15 : Counter used to generate a one time product code
- Digit 16 : Not used

Options

Options	No.	Description	Advantages	Use
Low Brine with turbulators down to -15°C	6	Redesigned evaporator including turbulators to allow chilled brine solution production with low pressure drops on the entire negative application range, down to -15°C (including turbulators, extra insulation and algorithms).	Covers specific applications such as ice storage and industrial processes	-0254-P1762
Light-brine solution, down to -3°C	8	Implementation of new control algorithms and redesigned evaporator to allow chilled brine solution production down to -3°C when ethylene glycol is used (0°C with propylene glycol)	Matches with most application requirements for ground-sourced heat pumps and fits with many industrial processes requirements	-0254-P1762
IP44 electrical protection level	20	Control box tightness reinforced Electrical box enclosure and outside electrical component following IEC 60529 standard	Permits unit installation in more severe environments	-0254-P1762
90-10 Copper-Nickel condensers	33	- Condenser tubes 90-10 Cu/Ni. - Condenser tube sheets clad with 90-10 Cu/Ni. - Waterboxes not treated against corrosion.	Improved resistance to corrosion	-0254-P1762
Unit supplied in two assembled parts	51	The unit is equipped with flanges that allow disassembly of the unit on site	Facilitates installation in plant rooms with limited access	-1652--1702, P1612-P1762
Lead/Lag operation	58	Unit equipped with supplementary water outlet temperature sensor kit (to be field installed) allowing Lead/Lag operation of two units connected in parallel	Optimised operation of two units connected in parallel operation with operating time equalisation	-0254-P1762
Single power connection point	81	Unit power connection via one main supply connection	Quick and easy installation	-1002--1702, P1012-P1762
No disconnect switch	82A	Unit without disconnect switch, but with short-circuit protection device	Permits an external electrical disconnect system for the unit (field-supplied), while ensuring unit short circuit protection	-0254-P1762
Evap. single pump power/control circuit	84	Unit equipped with an electrical power and control circuit for one pump evaporator side	Quick and easy installation: the control of fixed speed pumps is embedded in the unit control	-0254--1252, P0512-P1314
Evap. dual pumps power/control circuit	84D	Unit equipped with an electrical power and control circuit for two pumps evaporator side	Quick and easy installation: the control of fixed speed pumps is embedded in the unit control	-0254--1252, P0512-P1314
Cond. single pump power/control circuit	84R	Unit equipped with an electrical power and control circuit for one pump condenser side	Quick and easy installation: the control of fixed speed pumps is embedded in the unit control	-0254--1252, P0512-P1314
Condenser insulation	86	Thermal condenser insulation	Minimizes thermal dispersions condenser side (key option for heat pump or heat recovery applications)	-0254-P1762
Service valve set	92	Liquid line valve (evaporator inlet) and compressor suction line valve	Allow isolation of various refrigerant circuit components for simplified service and maintenance	-0254-P1762
Evaporator with one pass less	100C	Evaporator with one pass on the water side. Evaporator inlet and outlet on opposite sides.	Easy to install, depending on site. Reduced pressure drops	-0254-P1762
Condenser with one pass less	102C	Condenser with one pass on the water side. Condenser inlet and outlet on opposite sides.	Easy to install, depending on site. Reduced pressure drops	-0254-P1762

Options

Options	No.	Description	Advantages	Use
21 bar evaporator	104	Reinforced evaporator for extension of the maximum water-side service pressure to 21 bar (standard 10 bar)	Covers applications with a high water column evaporator side (typically high buildings)	-0254-P1762
21 bar condenser	104A	Reinforced condenser for extension of the maximum water-side service pressure to 21 bar (standard 10 bar)	Covers applications with a high water column condenser side (typically high buildings)	-0254-P1762
Reversed evaporator water connections	107	Evaporator with reversed water inlet/outlet	Easy installation on sites with specific requirements	-0254-P1762
Reversed condenser water connections	107A	Condenser with reversed water inlet/outlet	Easy installation on sites with specific requirements	-0254-P1762
Lon gateway	148D	Bi-directional communication board complying with Lon Talk protocol	Connects the unit by communication bus to a building management system	-0254-P1762
Bacnet over IP	149	Bi-directional high-speed communication using BACnet protocol over Ethernet network (IP)	Easy and high-speed connection by ethernet line to a building management system. Allows access to multiple unit parameters	-0254-P1762
Modbus over IP and RS485	149B	Bi-directional high-speed communication using Modbus protocol over Ethernet network (IP)	Easy and high-speed connection by ethernet line to a building management system. Allows access to multiple unit parameters	-0254-P1762
High condensing temperature	150	Optimized compressor for operation at high condensing temperature	Increased condenser leaving water temperature up to 63°C. Allows applications with high condensing temperature (heat pumps, installations with not generously sized dry coolers or more generally, installations with dry coolers in hot climate). NOTE: to ens	-0254--0354, P0512-P1762
Condensing temperature limitation	150B	Limitation of the maximum condenser leaving water temperature to 45°C	Reduced maximum power input and current absorption: power cables and protection elements can therefore be downsized	-0254-P1762
Control for low cond. temperature	152	Output signal (0-10 V) to control the condenser water inlet valve	Simple installation: for applications with cold water at condenser inlet (ex. ground-source, groundwater-source, superficial water-source applications) the signal permits to control a 2 or 3-way valve to maintain condenser water temperature (and so condensing pressure) at acceptable values	-0254-P1762
Dry cooler control	154	Adaptation of the control box for communication with the dry cooler via a bus. For dry cooler need to select the cabinet with option control cabinet manage by the chiller control	Easy system management, extended control capabilities of a remote dry cooler	-0254-P1762
Energy Management Module	156	EMM Control board with additional inputs/ outputs. See Energy Management Module option chapter	Extended remote control capabilities (Set-point reset, ice storage end, demand limits, boiler on/off command.)	-0254-P1762
7" user interface	158A	Control supplied with a 7 inch colour touch screen user interface	Enhanced ease of use.	-0254-P1762
Input contact for Refrigerant leak detection	159	0-10 V signal to report any refrigerant leakage in the unit directly on the controller (the leak detector itself must be supplied by the customer)	Immediate customer notification of refrigerant losses to the atmosphere, allowing timely corrective actions	-0254-P1762

Options

Options	No.	Description	Advantages	Use
Dual relief valves on 3-way valve	194	Three-way valve upstream of dual relief valves on the shell and tubes evaporator	Valve replacement and inspection facilitated without refrigerant loss. Comforms to European standard EN378/BGVD4	-0254-P1762
Compliance with Swiss regulations	197	Additional tests on the water heat exchangers: supply (additional of PED documents) supplementary certificates and test certifications	Conformance with Swiss regulations	-0254-P1762
Compliance with Russian regulations	199	EAC certification	Conformance with Russian regulations	-0254-P1762
Compliance with Australian regulations	200	Unit approved to Australian code	Conformance with Australian regulations	-0254-P1762
Low noise level	257	Evaporator sound insulation	3 dB(A) quieter than standard unit	-0402-P1762
Welded evaporator connection kit	266	Victaulic piping connections with welded joints	Easy installation	-0254-P1762
Welded condenser water connection kit	267	Victaulic piping connections with welded joints	Easy installation	-0254-P1762
Flanged evaporator water connection kit	268	Victaulic piping connections with flanged joints	Easy installation	-0254-P1762
Flanged condenser water connection kit	269	Victaulic piping connections with flanged joints	Easy installation	-0254-P1762
Thermal compressor insulation	271	The compressor is covered with a thermal insulation layer	Prevents air humidity to condensate on the compressor surface	-0254-P1762
230V electrical plug	284	230V AC power supply source provided with plug socket and transformer (180 VA, 0,8 Amps)	Permits connection of a laptop or an electrical device during unit commissioning or servicing	-0254-P1762
ABOUND HVAC Performance (Connectivity embedded)	298A	Factory mounted connectivity device including 4G Modem & Antenna and access to Digital Services during warranty period.	Complete real time unit monitoring with web access to data and alarms. Enables more comprehensive Digital Service offers and service plans.	-0254-P1762
ABOUND HVAC Performance (Connectivity embedded) – Non DSO	298B	Factory mounted connectivity device including 4G Modem & antenna. Subscription to Digital Services purchased through Carrier Service.	Enables real time unit monitoring with more comprehensive Digital Service offers and service plans.	-0254-P1762
Free-cooling dry cooler control	313	Control & connections to a Free Cooling Dry cooler 09PE or 09VE fitted with option FC control box	Easy system management, Extended control capabilities to a dry cooler used in Free Cooling mode	-0254-P1762
Compliance with UAE regulation	318	Additional label on the unit with rated power input, rated current and EER following AHRI 550/590	Compliance with ESMA standard UAE.S 5010-5:2019.	-0254-P1762
Compliance with Morocco regulation	327	Specifics documents according Morocco regulation	Conformance with Morocco regulations	-0254-P1762

Physical data, standard units

Standard-efficiency units

30XW--/30XWH-			254	304	354	402	452	552	602	652	702	802	
Heating													
Standard unit Full load performances*	HW1	Nominal capacity	kW	317	360	422	499	555	626	633	793	858	929
		COP	kW/kW	5,96	5,98	5,93	5,98	6,04	5,84	5,81	6,06	5,96	5,79
	HW2	Nominal capacity	kW	312	353	417	473	526	595	624	749	812	879
		COP	kW/kW	4,51	4,50	4,55	4,54	4,56	4,42	4,46	4,54	4,48	4,40
Seasonal energy efficiency**	HW1	SCOP _{30/35°C}	kWh/kWh	5,98	6,02	5,99	6,45	6,60	6,58	6,31	6,16	6,15	6,13
		η_s heat _{30/35°C}	%	231	233	231	250	256	255	245	238	238	237
		P _{rated}	kW	414	426	500	595	660	742	750	945	1022	1095
Cooling													
Standard unit Full load performances*	CW1	Nominal capacity	kW	269	303	354	421	467	525	531	669	720	783
		EER	kW/kW	5,25	5,23	5,17	5,22	5,28	5,12	5,11	5,32	5,23	5,13
	CW2	Nominal capacity	kW	264	320	396	525	566	520	596	753	788	782
		EER	kW/kW	7,30	5,74	6,31	6,50	6,40	5,24	5,86	6,02	5,76	5,22
Seasonal energy efficiency**		SEER_{12/7°C} Comfort low temp.	kWh/kWh	6,26	6,33	6,40	6,851	7,043	7,116	6,823	6,644	6,63	6,82
		η_s cool _{12/7°C}	%	247	250	253	271	279	282	270	263	262	270
		SEPR _{12/7°C} Process high temp.	kWh/kWh	8,60	8,16	8,80	8,12	8,28	7,72	7,90	8,83	8,25	8,01
Integrated Part Load Value	IPLV.SI	kW/kW	6,791	6,845	6,850	6,861	7,165	7,430	7,110	7,185	7,168	7,212	
Sound levels - standard unit													
Sound power level ^①		dB(A)	95	95	95	99	99	99	99	99	99	99	
Sound pressure level at 1 m ^②		dB(A)	78	78	78	82	82	82	82	82	82	82	
Sound levels - standard unit + option 257^③													
Sound power level ^①		dB(A)	-	-	-	96	96	96	96	96	96	96	
Sound pressure level at 1 m ^②		dB(A)	-	-	-	78	78	78	78	78	78	78	
Dimensions - standard unit													
Length		mm	2724	2724	2724	2741	2741	2741	2741	3059	3059	3059	
Width		mm	928	928	928	936	936	936	936	1040	1040	1040	
Height		mm	1567	1567	1567	1692	1692	1692	1692	1848	1848	1848	

* In accordance with standard EN14511-3:2022.
 ** In accordance with standard EN14825:2022, average climate
 HW1 Heating mode conditions: Evaporator entering/leaving water temperature 10°C/7°C, condenser entering/leaving water temperature 30°C/35°C, evaporator and condenser fouling factor 0 m². k/W
 HW2 Heating mode conditions: Evaporator entering/leaving water temperature 10°C/7°C, condenser entering/leaving water temperature 40°C/45°C, evaporator and condenser fouling factor 0 m². k/W
 CW1 Cooling mode conditions: Evaporator water entering/leaving temperature 12°C/7°C, condenser entering/leaving water temperature 30°C/35°C, evaporator and condenser fouling factor 0 m².K/W
 CW2 Cooling mode conditions: Evaporator water entering/leaving temperature 23°C/18°C, condenser entering/leaving water temperature 30°C/35°C, evaporator and condenser fouling factor 0 m².K/W
 η_s heat_{30/35°C} & SCOP_{30/35°C} Values calculated in accordance with EN14825:2022
 η_s cool_{12/7°C} & SEER_{12/7°C} **Bold values compliant to Ecodesign regulation: (EU) No 2016/2281 for Comfort application**
 SEPR_{12/7°C} Values calculated in accordance with EN14825:2022
 IPLV.SI Calculations according to standard performances AHRI 551-591 (SI).
 ① In dB ref=10¹² W, (A) weighting. Declared dualnumber noise emission values in accordance with ISO 4871 (with an associated uncertainty of +/-3dB(A)). Measured in accordance with ISO 9614-1 and certified by Eurovent.
 ② In dB ref 20μPa, (A) weighting. Declared dualnumber noise emission values in accordance with ISO 4871 (with an associated uncertainty of +/-3dB(A)). For information, calculated from the sound power level Lw(A).
 ③ Option 257 = Low noise level.



Eurovent certified values



AHRI certified values
30XW-only

Physical data, standard units

30XW--/30XWH-		254	304	354	402	452	552	602	652	702	802
Operating weight^④	kg	2017	2036	2072	2575	2575	2613	2644	3247	3266	3282
Compressors		Semi-hermetic 06T screw compressors, 50 r/s									
Circuit A	-	1	1	1	1	1	1	1	1	1	1
Circuit B	-	-	-	-	-	-	-	-	-	-	-
Refrigerant^⑤		R-134a									
Circuit A	kg	84	80	78	92	92	92	92	145	135	125
	teqCO ₂	120	114	112	132	132	132	132	207	193	179
Circuit B	kg	-	-	-	-	-	-	-	-	-	-
	teqCO ₂	-	-	-	-	-	-	-	-	-	-
Oil - standard unit											
Circuit A	l	23,5	23,5	23,5	32	32	32	32	36	36	36
Circuit B	l	-	-	-	-	-	-	-	-	-	-
Capacity control		SmartVu™, electronic expansion valves (EXV)									
Minimum capacity ^⑤	%	15	15	30	30	30	30	30	15	15	30
Evaporator		Multi-pipe flooded type									
Water volume	l	50	56	61	70	70	70	70	109	109	109
Water connections (Victaulic)	in	5	5	5	5	5	5	5	6	6	6
Drain and vent connections (NPT)	in	3/8	3/8	3/8	3/8	3/8	3/8	3/8	3/8	3/8	3/8
Max. water-side operating pressure	kPa	1000	1000	1000	1000	1000	1000	1000	1000	1000	1000
Condenser		Multi-pipe flooded type									
Water volume	l	55	55	55	76	76	76	76	109	109	109
Water connections (Victaulic)	in	5	5	5	5	5	5	5	6	6	6
Drain and vent connections (NPT)	in	3/8	3/8	3/8	3/8	3/8	3/8	3/8	3/8	3/8	3/8
Max. water-side operating pressure	kPa	1000	1000	1000	1000	1000	1000	1000	1000	1000	1000

④ Weight shown is guideline only. Please refer to the unit nameplate.

⑤ Minimum unit capacity corresponds to a physical state of the unit and is given for indication only. The actual capacity at this stage depends on operating conditions.

Physical data, standard units

Standard-efficiency units

30XW--/30XWH-		852	1002	1052	1154	1252	1352	1452	1552	1652	1702		
Heating													
Standard unit Full load performances*	HW1	Nominal capacity	kW	981	1185	1237	1324	1457	1557	1689	1795	1913	2001
		COP	kW/kW	5,98	5,77	5,67	5,79	6,12	5,96	5,76	5,61	5,94	5,92
	HW2	Nominal capacity	kW	958	1123	1174	1297	1375	1466	1592	1687	1867	1948
		COP	kW/kW	4,60	4,40	4,33	4,46	4,63	4,53	4,41	4,33	4,61	4,64
Seasonal energy efficiency**	HW1	SCOP _{30/35°C}	kWh/kWh	6,33	6,43	6,24	6,30	6,56	6,33	6,22	6,11	6,46	6,50
		η_s heat _{30/35°C}	%	245	249	242	244	254	245	241	236	251	252
		P _{rated}	kW	1153	1411	1473	1569	1737	1856	2013	2140	2265	2371
Cooling													
Standard unit Full load performances*	CW1	Nominal capacity	kW	829	1005	1049	1128	1242	1327	1438	1532	1637	1712
		EER	kW/kW	5,33	5,19	5,12	5,25	5,55	5,45	5,31	5,24	5,54	5,55
	CW2	Nominal capacity	kW	828	1188	1322	1220	1535	1677	1753	1865	1726	1830
		EER	kW/kW	5,43	6,93	6,30	5,75	6,72	6,71	6,30	6,36	5,95	5,91
Seasonal energy efficiency**		SEER_{12/7°C} Comfort low temp.	kWh/kWh	7,091	7,07	7,02	6,96	7,51	7,24	7,11	7,13	7,55	7,69
		η_s cool _{12/7°C}	%	281	280	278	275	298	287	282	282	299	304
		SEPR _{12/7°C} Process high temp.	kWh/kWh	8,01	8,29	8,11	7,96	8,97	9,09	8,34	8,13	8,45	8,50
Integrated Part Load Value	IPLV.SI	kW/kW	7,289	7,478	7,367	7,435	7,804	7,725	7,666	7,504	8,000	8,020	
Sound levels - standard unit													
Sound power level ^①		dB(A)	99	102	102	102	102	102	102	102	102	102	
Sound pressure level at 1 m ^②		dB(A)	82	84	84	84	83	83	83	83	83	83	
Sound levels - standard unit + option 257^③													
Sound power level ^①		dB(A)	96	99	99	99	99	99	99	99	99	99	
Sound pressure level at 1 m ^②		dB(A)	78	80	80	80	80	80	80	80	80	80	

* In accordance with standard EN14511-3:2022.
 ** In accordance with standard EN14825:2022, average climate
 HW1 Heating mode conditions: Evaporator entering/leaving water temperature 10°C/7°C, condenser entering/leaving water temperature 30°C/35°C, evaporator and condenser fouling factor 0 m². k/W
 HW2 Heating mode conditions: Evaporator entering/leaving water temperature 10°C/7°C, condenser entering/leaving water temperature 40°C/45°C, evaporator and condenser fouling factor 0 m². k/W
 CW1 Cooling mode conditions: Evaporator water entering/leaving temperature 12°C/7°C, condenser entering/leaving water temperature 30°C/35°C, evaporator and condenser fouling factor 0 m².K/W
 CW2 Cooling mode conditions: Evaporator water entering/leaving temperature 23°C/18°C, condenser entering/leaving water temperature 30°C/35°C, evaporator and condenser fouling factor 0 m².K/W
 η_s heat_{30/35°C} & SCOP_{30/35°C} Values calculated in accordance with EN14825:2022
 η_s cool_{12/7°C} & SEER_{12/7°C} **Bold values compliant to Ecodesign regulation: (EU) No 2016/2281 for Comfort application**
 SEPR_{12/7°C} Values calculated in accordance with EN14825:2022
 IPLV.SI Calculations according to standard performances AHRI 551-591 (SI).
 ① In dB ref=10¹² W, (A) weighting. Declared dualnumber noise emission values in accordance with ISO 4871 (with an associated uncertainty of +/-3dB(A)). Measured in accordance with ISO 9614-1 and certified by Eurovent.
 ② In dB ref 20μPa, (A) weighting. Declared dualnumber noise emission values in accordance with ISO 4871 (with an associated uncertainty of +/-3dB(A)). For information, calculated from the sound power level Lw(A).
 ③ Option 257 = Low noise level.



Eurovent certified values



AHRI certified values
30XW-only

CARRIER participates in the ECP programme for LCP-HP Check ongoing validity of certificate: www.eurovent-certification.com

Physical data, standard units

30XW--/30XWH-		852	1002	1052	1154	1252	1352	1452	1552	1652	1702
Dimensions - standard unit											
Length	mm	2780	4025	4025	4025	4730	4730	4730	4730	4790	4790
Width	mm	1042	1036	1036	1036	1156	1156	1156	1156	1902	1902
Height	mm	1898	1870	1870	1925	2051	2051	2051	2051	1515	1515
Operating weight^④	kg	3492	5370	5408	5698	7066	7267	7305	7337	8681	8699
Compressors											
Semi-hermetic 06T screw compressors, 50 r/s											
Circuit A	-	1	1	1	1	1	1	1	1	1	1
Circuit B	-	-	1	1	1	1	1	1	1	1	1
Refrigerant^⑤											
R-134a											
Circuit A	kg	158	85	85	105	120	115	110	105	195	195
	teqCO ₂	226	122	122	150	172	164	157	150	279	279
Circuit B	kg	-	85	85	105	120	115	110	105	195	195
	teqCO ₂	-	122	122	150	172	164	157	150	279	279
Oil - standard unit											
Circuit A	l	36	32	32	32	36	36	36	36	36	36
Circuit B	l	-	32	32	32	32	36	36	36	36	36
Capacity control											
SmartVu™, electronic expansion valves (EXV)											
Minimum capacity ^⑤	%	30	30	30	30	15	15	15	30	30	30
Evaporator											
Multi-pipe flooded type											
Water volume	l	98	182	182	205	301	301	301	301	354	354
Water connections (Victaulic)	in	6	6	6	8	8	8	8	8	8	8
Drain and vent connections (NPT)	in	3/8	3/8	3/8	3/8	3/8	3/8	3/8	3/8	3/8	3/8
Max. water-side operating pressure	kPa	1000	1000	1000	1000	1000	1000	1000	1000	1000	1000
Condenser											
Multi-pipe flooded type											
Water volume	l	137	193	193	193	340	340	340	340	426	426
Water connections (Victaulic)	in	8	8	8	8	8	8	8	8	8	8
Drain and vent connections (NPT)	in	3/8	3/8	3/8	3/8	3/8	3/8	3/8	3/8	3/8	3/8
Max. water-side operating pressure	kPa	1000	1000	1000	1000	1000	1000	1000	1000	1000	1000

④ Weight shown is guideline only. Please refer to the unit nameplate.

⑤ Minimum unit capacity corresponds to a physical state of the unit and is given for indication only. The actual capacity at this stage depends on operating conditions.

Physical data, standard units

High-efficiency units

30XW-P/30XWHP		512	562	712	812	862	1012	1162	1314	1464	1612	1762		
Heating														
Standard unit Full load performances*	HW1	Nominal capacity	kW	586	667	851	912	995	1201	1327	1522	1680	1863	2019
		COP	kW/kW	6,36	6,30	6,52	6,29	6,27	6,35	6,24	6,29	6,06	6,38	6,27
	HW2	Nominal capacity	kW	573	654	836	896	970	1179	1296	1489	1643	1823	1964
		COP	kW/kW	4,82	4,78	4,92	4,74	4,78	4,85	4,77	4,82	4,66	4,84	4,81
Seasonal energy efficiency**	HW1	SCOP _{30/35°C}	kWh/kWh	6,58	6,59	6,48	6,27	6,48	6,72	6,85	6,75	6,38	6,73	6,71
		η _s heat _{30/35°C}	%	255	256	251	243	251	261	266	262	247	261	260
		P _{rated}	kW	694	791	1009	1081	1180	1424	1572	1805	1993	2210	2395
Cooling														
Standard unit Full load performances*	CW1	Nominal capacity	kW	502	569	727	776	850	1025	1143	1308	1435	1606	1736
		EER	kW/kW	5,63	5,57	5,75	5,55	5,59	5,67	5,71	5,74	5,53	5,80	5,72
	CW2	Nominal capacity	kW	546	643	788	859	886	1217	1251	1554	1687	1802	1865
		EER	kW/kW	6,36	6,38	6,62	6,44	6,28	7,29	6,30	8,19	6,69	6,75	6,54
Seasonal energy efficiency**		SEER_{12/7°C} Comfort low temp.	kWh/kWh	7,00	7,12	7,05	6,82	7,24	7,34	7,78	7,69	7,29	7,79	7,86
		η _s cool _{12/7°C}	%	277	282	279	270	287	291	308	304	289	309	311
		SEPR _{12/7°C} Process high temp.	kWh/kWh	8,42	8,50	9,23	8,33	8,54	8,50	8,85	9,00	8,89	8,82	8,83
Integrated Part Load Value	IPLV.SI	kW/kW	7,391	7,473	7,556	7,301	7,538	7,639	8,053	8,150	7,485	7,757	8,089	
Sound levels - standard unit														
Sound power level ^①		dB(A)	99	99	99	99	99	102	102	102	102	102	102	
Sound pressure level at 1 m ^②		dB(A)	82	82	81	81	81	83	83	83	83	83	83	
Sound levels - standard unit + option 257^③														
Sound power level ^①		dB(A)	96	96	96	96	96	99	99	99	99	99	99	
Sound pressure level at 1 m ^②		dB(A)	78	78	78	78	78	80	80	80	80	80	80	

* In accordance with standard EN14511-3:2022.
 ** In accordance with standard EN14825:2022, average climate
 HW1 Heating mode conditions: Evaporator entering/leaving water temperature 10°C/7°C, condenser entering/leaving water temperature 30°C/35°C, evaporator and condenser fouling factor 0 m². k/W
 HW2 Heating mode conditions: Evaporator entering/leaving water temperature 10°C/7°C, condenser entering/leaving water temperature 40°C/45°C, evaporator and condenser fouling factor 0 m². k/W
 CW1 Cooling mode conditions: Evaporator water entering/leaving temperature 12°C/7°C, condenser entering/leaving water temperature 30°C/35°C, evaporator and condenser fouling factor 0 m². K/W
 CW2 Cooling mode conditions: Evaporator water entering/leaving temperature 23°C/18°C, condenser entering/leaving water temperature 30°C/35°C, evaporator and condenser fouling factor 0 m². K/W
 η_s heat_{30/35°C} & SCOP_{30/35°C} Values calculated in accordance with EN14825:2022
 η_s cool_{12/7°C} & SEER_{12/7°C} **Bold values compliant to Ecodesign regulation: (EU) No 2016/2281 for Comfort application**
 SEPR_{12/7°C} Values calculated in accordance with EN14825:2022
 IPLV.SI Calculations according to standard performances AHRI 551-591 (SI).
 ① In dB ref=10¹² W, (A) weighting. Declared dualnumber noise emission values in accordance with ISO 4871 (with an associated uncertainty of +/-3dB(A)). Measured in accordance with ISO 9614-1 and certified by Eurovent.
 ② In dB ref 20μPa, (A) weighting. Declared dualnumber noise emission values in accordance with ISO 4871 (with an associated uncertainty of +/-3dB(A)). For information, calculated from the sound power level Lw(A).
 ③ Option 257 = Low noise level.



Eurovent certified values



AHRI certified values
30XW-only

CARRIER participates in the ECP programme for LCP-HP Check ongoing validity of certificate: www.eurovent-certification.com

Physical data, standard units

30XW-P/30XWHP		512	562	712	812	862	1012	1162	1314	1464	1612	1762
Dimensions - standard unit												
Length	mm	3059	3059	3290	3290	3290	4730	4730	4730	4730	4832	4832
Width	mm	936	936	1069	1069	1069	1039	1039	1162	1162	2129	2129
Height	mm	1743	1743	1950	1950	1950	1997	1997	2051	2051	1562	1562
Operating weight^④	kg	2981	3020	3912	3947	3965	6872	6950	7542	7752	10910	10946
Compressors		Semi-hermetic O6T screw compressors, 50 r/s										
Circuit A	-	1	1	1	1	1	1	1	1	1	1	1
Circuit B	-	-	-	-	-	-	1	1	1	1	1	1
Refrigerant^⑤		R-134a										
Circuit A	kg	130	130	180	175	177	120	120	130	130	240	250
	teqCO ₂	186	186	257	250	253	172	172	186	186	343	358
Circuit B	kg	-	-	-	-	-	120	120	150	130	240	250
	teqCO ₂	-	-	-	-	-	172	172	215	186	343	358
Oil - standard unit												
Circuit A	l	32	32	36	36	36	32	32	36	36	36	36
Circuit B	l	-	-	-	-	-	32	32	32	36	36	36
Capacity control		SmartVu™, electronic expansion valves (EXV)										
Minimum capacity ^⑤	%	30	30	15	15	30	30	30	15	15	15	30
Evaporator		Multi-pipe flooded type										
Water volume	l	101	101	154	154	154	293	293	321	321	473	473
Water connections (Victaulic)	in	6	6	8	8	8	8	8	8	8	10	10
Drain and vent connections (NPT)	in	3/8	3/8	3/8	3/8	3/8	3/8	3/8	3/8	3/8	3/8	3/8
Max. water-side operating pressure	kPa	1000	1000	1000	1000	1000	1000	1000	1000	1000	1000	1000
Condenser		Multi-pipe flooded type										
Water volume	l	103	103	148	148	148	316	316	340	340	623	623
Water connections (Victaulic)	in	6	6	8	8	8	8	8	8	8	10	10
Drain and vent connections (NPT)	in	3/8	3/8	3/8	3/8	3/8	3/8	3/8	3/8	3/8	3/8	3/8
Max. water-side operating pressure	kPa	1000	1000	1000	1000	1000	1000	1000	1000	1000	1000	1000

④ Weight shown is guideline only. Please refer to the unit nameplate.

⑤ Minimum unit capacity corresponds to a physical state of the unit and is given for indication only. The actual capacity at this stage depends on operating conditions.

Electrical data, standard units

Standard-efficiency units

30XW--/30XWH-		254	304	354	402	452	552	602	652	702	802
Power circuit											
Nominal power supply	V-ph-Hz	400-3-50									
Voltage range	V	360-440									
Control circuit											
24 V via the built-in transformer											
Nominal start-up current^①											
Circuit A	A	233	233	303	414	414	414	414	587	587	587
Circuit B	A	-	-	-	-	-	-	-	-	-	-
Option 81	A	-	-	-	-	-	-	-	-	-	-
Maximum start-up current^②											
Circuit A	A	233	233	303	414	414	414	414	587	587	587
Circuit B	A	-	-	-	-	-	-	-	-	-	-
Option 81	A	-	-	-	-	-	-	-	-	-	-
Cosine phi											
Nominal ^③		0,83	0,85	0,83	0,87	0,88	0,89	0,89	0,88	0,89	0,90
Maximum ^④		0,89	0,89	0,88	0,90	0,90	0,91	0,91	0,90	0,91	0,92
Total harmonic distortion ^⑤	%	0	0	0	0	0	0	0	0	0	0
Maximum power input^⑥											
Circuit A	kW	76	89	97	128	135	151	151	184	200	223
Circuit B	kW	-	-	-	-	-	-	-	-	-	-
Option 81	kW	-	-	-	-	-	-	-	-	-	-
Nominal current drawn^⑦											
Circuit A	A	84	96	113	136	144	162	162	193	214	232
Circuit B	A	-	-	-	-	-	-	-	-	-	-
Option 81	A	-	-	-	-	-	-	-	-	-	-
Maximum current drawn (Un)^⑧											
Circuit A	A	123	145	160	206	217	242	242	295	317	351
Circuit B	A	-	-	-	-	-	-	-	-	-	-
Option 81	A	-	-	-	-	-	-	-	-	-	-
Maximum current drawn (Un -10%)^⑨											
Circuit A	A	138	162	178	218	230	260	260	304	340	358
Circuit B	A	-	-	-	-	-	-	-	-	-	-
Option 81	A	-	-	-	-	-	-	-	-	-	-
Maximum power input with option 150B^⑩											
Circuit A	kW	67	79	87	114	118	133	134	173	183	205
Circuit B	kW	-	-	-	-	-	-	-	-	-	-
Option 81	kW	-	-	-	-	-	-	-	-	-	-
Maximum current drawn (Un) with option 150B^⑪											
Circuit A	A	109	129	142	183	191	212	212	278	290	325
Circuit B	A	-	-	-	-	-	-	-	-	-	-
Option 81	A	-	-	-	-	-	-	-	-	-	-

① Instantaneous start-up current (maximum operating current of the smallest compressor(s) + locked rotor current or reduced start-up current of the largest compressor). Values obtained at standard Eurovent unit operating conditions: evaporator entering/leaving water temperature = 12°C/7°C, condenser entering/leaving water temperature = 30°C/35°C.

② Instantaneous start-up current (maximum operating current of the smallest compressor(s) + locked rotor current or reduced start-up current of the largest compressor). Values obtained at operation with maximum unit power input.

③ Values obtained at standard Eurovent unit operating conditions: evaporator entering/leaving water temperature = 12°C/7°C, condenser entering/leaving water temperature = 30°C/35°C.

④ Values obtained at operation with maximum unit power input.

⑤ Values obtained at operation with maximum unit power input. Values given on the unit name plate.

Electrical data, standard units

Standard-efficiency units

30XW--/30XWH-		852	1002	1052	1154	1252	1352	1452	1552	1652	1702
Power circuit											
Nominal power supply	V-ph-Hz	400-3-50									
Voltage range	V	360-440									
Control circuit											
24 V via the built-in transformer											
Nominal start-up current^①											
Circuit A	A	587	414	414	414	587	587	587	587	587	587
Circuit B	A	-	414	414	414	414	587	587	587	587	587
Option 81	A	-	558	574	574	747	780	801	819	819	819
Maximum start-up current^②											
Circuit A	A	587	414	414	414	587	587	587	587	587	587
Circuit B	A	-	414	414	414	414	587	587	587	587	587
Option 81	A	-	631	656	656	829	882	904	938	938	938
Cosine phi											
Nominal ^③		0,90	0,88	0,89	0,89	0,88	0,88	0,89	0,9	0,9	0,9
Maximum ^④		0,92	0,90	0,91	0,91	0,90	0,90	0,91	0,92	0,92	0,92
Total harmonic distortion ^⑤	%	0	0	0	0	0	0	0	0	0	0
Maximum power input^⑤											
Circuit A	kW	223	150	151	151	184	184	200	223	223	223
Circuit B	kW	-	135	151	151	151	184	200	223	202	223
Option 81	kW	-	284	301	301	334	367	399	447	425	447
Nominal current drawn^⑤											
Circuit A	A	232	162	162	162	193	193	214	232	232	232
Circuit B	A	-	144	162	162	162	193	214	232	214	232
Option 81	A	-	306	324	324	355	386	427	464	446	464
Maximum current drawn (Un)^⑤											
Circuit A	A	351	242	242	242	295	295	317	351	351	351
Circuit B	A	-	217	242	242	242	295	317	351	317	351
Option 81	A	-	459	484	484	537	590	634	702	668	702
Maximum current drawn (Un -10%)^⑤											
Circuit A	A	358	260	260	260	304	304	340	358	358	358
Circuit B	A	-	230	260	260	260	304	340	358	340	358
Option 81	A	-	490	520	520	564	608	680	716	698	716
Maximum power input with option 150B^⑤											
Circuit A	kW	205	133	133	133	173	173	183	207	207	207
Circuit B	kW	-	118	133	133	133	173	183	207	185	207
Option 81	kW	-	251	265	265	305	346	365	414	391	414
Maximum current drawn (Un) with option 150B^⑤											
Circuit A	A	325	212	212	212	278	278	290	325	325	325
Circuit B	A	-	191	212	212	212	278	290	325	290	325
Option 81	A	-	403	424	424	490	556	580	650	615	650

- ① Instantaneous start-up current (maximum operating current of the smallest compressor(s) + locked rotor current or reduced start-up current of the largest compressor). Values obtained at standard Eurovent unit operating conditions: evaporator entering/leaving water temperature = 12°C/7°C, condenser entering/leaving water temperature = 30°C/35°C.
- ② Instantaneous start-up current (maximum operating current of the smallest compressor(s) + locked rotor current or reduced start-up current of the largest compressor). Values obtained at operation with maximum unit power input.
- ③ Values obtained at standard Eurovent unit operating conditions: evaporator entering/leaving water temperature = 12°C/7°C, condenser entering/leaving water temperature = 30°C/35°C.
- ④ Values obtained at operation with maximum unit power input.
- ⑤ Values obtained at operation with maximum unit power input. Values given on the unit name plate.

Electrical data, standard units

High-efficiency units

30XW-P/30XWHP		512	562	712	812	862	1012	1162	1314	1464	1612	1762
Power circuit												
Nominal power supply	V-ph-Hz	400-3-50										
Voltage range	V	360-440										
Control circuit												
24 V via the built-in transformer												
Nominal start-up current^①												
Circuit A	A	414	414	587	587	587	414	414	587	587	587	587
Circuit B	A	-	-	-	-	-	414	414	414	587	587	587
Option 81	A	-	-	-	-	-	556	574	747	780	801	819
Maximum start-up current^②												
Circuit A	A	414	414	587	587	587	414	414	587	587	587	587
Circuit B	A	-	-	-	-	-	414	414	414	587	587	587
Option 81	A	-	-	-	-	-	631	656	829	882	904	938
Cosine phi												
Nominal ^③		0,88	0,89	0,88	0,89	0,90	0,86	0,87	0,88	0,88	0,89	0,90
Maximum ^④		0,90	0,90	0,90	0,91	0,92	0,89	0,90	0,90	0,90	0,91	0,92
Total harmonic distortion ^⑤	%	0	0	0	0	0	0	0	0	0	0	0
Maximum power input^⑥												
Circuit A	kW	135	151	184	200	223	134	151	184	184	200	223
Circuit B	kW	-	-	-	-	-	134	151	151	184	200	223
Option 81	kW	-	-	-	-	-	267	301	334	367	399	447
Nominal current drawn^⑦												
Circuit A	A	144	162	193	214	232	144	162	193	193	214	232
Circuit B	A	-	-	-	-	-	144	162	162	193	214	232
Option 81	A	-	-	-	-	-	288	324	355	386	427	464
Maximum current drawn (Un)^⑧												
Circuit A	A	217	242	295	317	351	217	242	295	295	317	351
Circuit B	A	-	-	-	-	-	217	242	242	295	317	351
Option 81	A	-	-	-	-	-	434	484	537	590	634	702
Maximum current drawn (Un -10%)^⑨												
Circuit A	A	230	260	304	340	358	230	260	304	304	340	358
Circuit B	A	-	-	-	-	-	230	260	260	304	340	358
Option 81	A	-	-	-	-	-	460	520	564	608	680	716
Maximum power input with option 150B^⑩												
Circuit A	kW	118	133	173	183	207	118	133	173	173	183	207
Circuit B	kW	-	-	-	-	-	118	133	133	173	183	207
Option 81	kW	-	-	-	-	-	235	265	305	346	365	414
Maximum current drawn (Un) with option 150B^⑩												
Circuit A	A	191	212	278	290	325	191	212	278	278	290	325
Circuit B	A	-	-	-	-	-	191	212	212	278	290	325
Option 81	A	-	-	-	-	-	382	424	490	556	580	650

① Instantaneous start-up current (maximum operating current of the smallest compressor(s) + locked rotor current or reduced start-up current of the largest compressor). Values obtained at standard Eurovent unit operating conditions: evaporator entering/leaving water temperature = 12°C/7°C, condenser entering/leaving water temperature = 30°C/35°C.

② Instantaneous start-up current (maximum operating current of the smallest compressor(s) + locked rotor current or reduced start-up current of the largest compressor). Values obtained at operation with maximum unit power input.

③ Values obtained at standard Eurovent unit operating conditions: evaporator entering/leaving water temperature = 12°C/7°C, condenser entering/leaving water temperature = 30°C/35°C

④ Values obtained at operation with maximum unit power input.

⑤ Values obtained at operation with maximum unit power input. Values given on the unit name plate.

Physical data, units for high condensing temperatures

Standard-efficiency units (option 150)

30XW--/30XWH-		254	304	354	402	452	552	602	652	702	802		
Heating													
Unit + option 150 Full load performances*	HW1	Nominal capacity	kW	328	366	413	502	536	597	618	756	845	869
		COP	kW/kW	5,49	5,48	5,44	5,11	5,41	5,27	5,41	5,31	5,37	5,17
	HW2	Nominal heating capacity	kW	319	356	402	470	501	559	599	706	789	812
		COP	kW/kW	4,54	4,51	4,47	4,21	4,45	4,36	4,48	4,39	4,44	4,31
	HW3	Nominal capacity	kW	310	347	391	440	469	523	582	659	738	760
		COP	kW/kW	3,80	3,78	3,75	3,47	3,67	3,61	3,76	3,62	3,68	3,57
Seasonal energy efficiency**	HW1	SCOP _{30/35°C}	kWh/kWh	5,77	5,94	5,86	5,54	5,77	5,75	5,72	5,55	5,79	5,01
		η _{s heat} 30/35°C	%	223	230	226	214	223	222	221	214	223	193
	HW3	SCOP _{47/55°C}	kWh/kWh	4,58	4,63	4,56	4,20	4,42	4,45	4,50	4,26	4,45	3,86
		η _{s heat} 47/55°C	%	175	177	175	160	169	170	172	163	170	146
		P _{rated}	kW	411	415	467	535	571	637	697	803	898	926
	Cooling												
Unit + option 150 Full load performances*	CW1	Nominal cooling capacity	kW	278	309	348	NA	NA	NA	NA	NA	NA	NA
		EER	kW/kW	4,83	4,80	4,76	NA	NA	NA	NA	NA	NA	NA
Seasonal energy efficiency**		SEER_{12/7°C} Comfort low temp.	kWh/kWh	6,19	6,29	6,22	NA	NA	NA	NA	NA	NA	NA
		η_{s cool} 12/7°C	%	245	249	246	NA	NA	NA	NA	NA	NA	NA
		SEPR _{12/7°C} Process high temp.	kWh/kWh	6,67	6,72	6,57	NA	NA	NA	NA	NA	NA	NA
Integrated Part Load Value	IPLV.SI	kW/kW	6,364	6,527	6,531	5,928	6,176	6,287	6,185	5,931	6,433	5,575	
Sound levels - unit with option 150													
Sound power level ^①		dB(A)	95	95	95	99	99	99	99	102	102	102	
Sound pressure level at 1 m ^②		dB(A)	78	78	78	82	82	82	82	84	84	84	
Sound levels - unit with option 150 + option 257^③													
Sound power level ^①		dB(A)	-	-	-	96	96	96	96	100	100	100	
Sound pressure level at 1 m ^②		dB(A)	-	-	-	78	78	78	78	82	82	82	

* In accordance with standard EN14511-3:2022.
 ** In accordance with standard EN14825:2022, average climate
 HW1 Heating mode conditions: Evaporator entering/leaving water temperature 10°C/7°C, condenser entering/leaving water temperature 30°C/35°C, evaporator and condenser fouling factor 0 m². k/W
 HW2 Heating mode conditions: Evaporator entering/leaving water temperature 10°C/7°C, condenser entering/leaving water temperature 40°C/45°C, evaporator and condenser fouling factor 0 m². k/W
 HW3 Heating mode conditions: Evaporator entering/leaving water temperature 10°C/7°C, condenser entering/leaving water temperature 47°C/55°C, evaporator and condenser fouling factor 0 m². k/W
 CW1 Cooling mode conditions: Evaporator water entering/leaving temperature 12°C/7°C, condenser entering/leaving water temperature 30°C/35°C, evaporator and condenser fouling factor 0 m². K/W
 η_{s heat} 30/35°C & SCOP_{30/35°C} Values calculated in accordance with EN14825:2022
 η_{s heat} 47/55°C & SCOP_{47/55°C} Values calculated in accordance with EN14825:2022
 η_{s cool} 12/7°C & SEER_{12/7°C} **Bold values compliant to Ecodesign regulation: (EU) No 2016/2281 for Comfort application**
 SEPR_{12/7°C} Values calculated in accordance with EN14825:2022
 IPLV.SI Calculations according to standard performances AHRI 551-591 (SI).
 NA Non Authorized for the specific application for CEE market
 ① In dB ref=10¹² W, (A) weighting. Declared dual number noise emission values in accordance with ISO 4871 (with an associated uncertainty of +/-3dB(A)). Measured in accordance with ISO 9614-1 and certified by Eurovent.
 ② In dB ref 20μPa, (A) weighting. Declared dual number noise emission values in accordance with ISO 4871 (with an associated uncertainty of +/-3dB(A)). For information, calculated from the sound power level Lw(A).
 ③ Option 257 = Low noise level



Eurovent certified values



AHRI certified values
30XW-only

CARRIER participates in the ECP programme for LCP-HP Check ongoing validity of certificate: www.eurovent-certification.com

Physical data, units for high condensing temperatures

30XW--/30XWH-		254	304	354	402	452	552	602	652	702	802
Dimensions - unit with option 150											
Length	mm	2724	2724	2724	2741	2741	2741	2741	3059	3059	3059
Width	mm	928	928	928	936	936	936	936	1090	1090	1090
Height	mm	1567	1567	1567	1692	1692	1692	1692	1858	1858	1858
Operating weight^①	kg	2017	2036	2072	2575	2575	2613	2644	3407	3438	3462
Compressors											
Semi-hermetic O6T screw compressors, 50 r/s											
Circuit A	-	1	1	1	1	1	1	1	1	1	1
Circuit B	-	-	-	-	-	-	-	-	-	-	-
Refrigerant^②											
R-134a											
Circuit A	kg	84	80	78	92	92	92	92	145	135	125
	teqCO ₂	120	114	112	132	132	132	132	207	193	179
Circuit B	kg	-	-	-	-	-	-	-	-	-	-
	teqCO ₂	-	-	-	-	-	-	-	-	-	-
Oil - unit with option 150											
Circuit A	l	23,5	23,5	23,5	32	32	32	32	36	36	36
Circuit B	l	-	-	-	-	-	-	-	-	-	-
Capacity control											
SmartVu™, electronic expansion valves (EXV)											
Minimum capacity ^③	%	30	30	30	30	30	30	30	25	25	25
Evaporator											
Multi-pipe flooded type											
Water volume	l	50	56	61	70	70	70	70	109	109	109
Water connections (Victaulic)	in	5	5	5	5	5	5	5	6	6	6
Drain and vent connections (NPT)	in	3/8	3/8	3/8	3/8	3/8	3/8	3/8	3/8	3/8	3/8
Max. water-side operating pressure	kPa	1000	1000	1000	1000	1000	1000	1000	1000	1000	1000
Condenser											
Multi-pipe flooded type											
Water volume	l	55	55	55	76	76	76	76	109	109	109
Water connections (Victaulic)	in	5	5	5	5	5	5	5	6	6	6
Drain and vent connections (NPT)	in	3/8	3/8	3/8	3/8	3/8	3/8	3/8	3/8	3/8	3/8
Max. water-side operating pressure	kPa	1000	1000	1000	1000	1000	1000	1000	1000	1000	1000

① Weight shown is guideline only. Please refer to the unit nameplate

③ Minimum unit capacity corresponds to a physical state of the unit and is given for indication only. The actual capacity at this stage depends on operating conditions.

Physical data, units for high condensing temperatures

Standard-efficiency units (option 150)

30XW--/30XWH-		852	1002	1052	1154	1252	1352	1452	1552	1652	1702		
Heating													
Unit + option 150 Full load performances*	HW1	Nominal capacity	kW	963	1163	1228	1338	1432	1551	1671	1776	1928	1991
		COP	kW/kW	5,36	5,37	5,28	5,38	5,56	5,32	5,23	5,12	5,34	5,27
	HW2	Nominal heating capacity	kW	939	1085	1146	1290	1329	1445	1558	1649	1873	1936
		COP	kW/kW	4,46	4,46	4,40	4,48	4,63	4,45	4,38	4,34	4,50	4,46
	HW3	Nominal capacity	kW	915	1012	1068	1249	1244	1345	1452	1543	1821	1882
		COP	kW/kW	3,73	3,71	3,66	3,77	3,83	3,68	3,64	3,63	3,81	3,77
Seasonal energy efficiency**	HW1	SCOP _{30/35°C}	kWh/kWh	5,66	5,86	5,86	5,78	6,09	5,69	5,79	5,43	5,93	5,92
		ηs heat _{30/35°C}	%	218	226	226	223	236	220	224	209	229	229
	HW3	SCOP _{47/55°C}	kWh/kWh	4,47	4,73	4,73	4,61	4,68	4,38	4,45	4,35	4,74	4,76
		ηs heat _{47/55°C}	%	171	181	181	176	179	167	170	166	182	182
		P _{rated}	kW	1094	1234	1303	1497	1518	1641	1770	1882	2179	2253
	Cooling												
Unit + option 150 Full load performances*	CW1	Nominal cooling capacity	kW	NA	NA	NA	NA	NA	NA	NA	NA	NA	NA
		EER	kW/kW	NA	NA	NA	NA	NA	NA	NA	NA	NA	NA
Seasonal energy efficiency**		SEER_{12/7°C} Comfort low temp.	kWh/kWh	NA	NA	NA	NA	NA	NA	NA	NA	NA	NA
		ηs cool_{12/7°C}	%	NA	NA	NA	NA	NA	NA	NA	NA	NA	NA
		SEPR _{12/7°C} Process high temp.	kWh/kWh	NA	NA	NA	NA	NA	NA	NA	NA	NA	NA
Integrated Part Load Value	IPLV.SI	kW/kW	6,351	6,572	6,595	6,522	6,873	6,211	6,615	6,366	6,939	7,136	
Sound levels - unit with option 150													
Sound power level ^①		dB(A)	102	102	102	102	105	105	105	105	105	105	
Sound pressure level at 1 m ^②		dB(A)	84	84	84	84	86	86	86	86	86	86	
Sound levels - unit with option 150 + option 257^③													
Sound power level ^①		dB(A)	100	99	99	99	103	103	103	103	103	103	
Sound pressure level at 1 m ^②		dB(A)	82	80	80	80	84	84	84	84	84	84	

* In accordance with standard EN14511-3:2022.
 ** In accordance with standard EN14825:2022, average climate
 HW1 Heating mode conditions: Evaporator entering/leaving water temperature 10°C/7°C, condenser entering/leaving water temperature 30°C/35°C, evaporator and condenser fouling factor 0 m². k/W
 HW2 Heating mode conditions: Evaporator entering/leaving water temperature 10°C/7°C, condenser entering/leaving water temperature 40°C/45°C, evaporator and condenser fouling factor 0 m². k/W
 HW3 Heating mode conditions: Evaporator entering/leaving water temperature 10°C/7°C, condenser entering/leaving water temperature 47°C/55°C, evaporator and condenser fouling factor 0 m². k/W
 CW1 Cooling mode conditions: Evaporator water entering/leaving temperature 12°C/7°C, condenser entering/leaving water temperature 30°C/35°C, evaporator and condenser fouling factor 0 m². K/W
 ηs heat_{30/35°C} & SCOP_{30/35°C} Values calculated in accordance with EN14825:2022
 ηs heat_{47/55°C} & SCOP_{47/55°C} Values calculated in accordance with EN14825:2022
 ηs cool_{12/7°C} & SEER_{12/7°C} **Bold values compliant to Ecodesign regulation: (EU) No 2016/2281 for Comfort application**
 SEPR_{12/7°C} Values calculated in accordance with EN14825:2022
 IPLV.SI Calculations according to standard performances AHRI 551-591 (SI).
 NA Non Authorized for the specific application for CEE market
 ① In dB ref=10¹² W, (A) weighting. Declared dual number noise emission values in accordance with ISO 4871 (with an associated uncertainty of +/-3dB(A)). Measured in accordance with ISO 9614-1 and certified by Eurovent.
 ② In dB ref 20μPa, (A) weighting. Declared dual number noise emission values in accordance with ISO 4871 (with an associated uncertainty of +/-3dB(A)). For information, calculated from the sound power level Lw(A).
 ③ Option 257 = Low noise level



Eurovent certified values



AHRI certified values
30XW-only

CARRIER participates in the ECP programme for LCP-HP Check ongoing validity of certificate: www.eurovent-certification.com

Physical data, units for high condensing temperatures

30XW--/30XWH-		852	1002	1052	1154	1252	1352	1452	1552	1652	1702
Dimensions - unit with option 150											
Length	mm	2780	4025	4025	4025	4730	4730	4730	4730	4790	4790
Width	mm	1090	1036	1036	1036	1201	1201	1201	1201	1947	1947
Height	mm	1920	1870	1870	1925	2071	2071	2071	2071	1535	1535
Operating weight[Ⓒ]	kg	3672	5370	5408	5698	7233	7554	7622	7670	9006	9032
Compressors		Semi-hermetic O6T screw compressors, 50 r/s									
Circuit A	-	1	1	1	1	1	1	1	1	1	1
Circuit B	-	-	1	1	1	1	1	1	1	1	1
Refrigerant[Ⓒ]		R-134a									
Circuit A	kg	158	85	85	105	120	115	110	105	195	195
	teqCO ₂	226	122	122	150	172	164	157	150	279	279
Circuit B	kg	-	85	85	105	120	115	110	105	195	195
	teqCO ₂	-	122	122	150	172	164	157	150	279	279
Oil - unit with option 150											
Circuit A	l	36	32	32	32	36	36	36	36	36	36
Circuit B	l	-	32	32	32	32	36	36	36	36	36
Capacity control		SmartVu™, electronic expansion valves (EXV)									
Minimum capacity [Ⓒ]	%	25	15	15	15	15	10	10	10	10	10
Evaporator		Multi-pipe flooded type									
Water volume	l	98	182	182	205	301	301	301	301	354	354
Water connections (Victaulic)	in	6	6	6	8	8	8	8	8	8	8
Drain and vent connections (NPT)	in	3/8	3/8	3/8	3/8	3/8	3/8	3/8	3/8	3/8	3/8
Max. water-side operating pressure	kPa	1000	1000	1000	1000	1000	1000	1000	1000	1000	1000
Condenser		Multi-pipe flooded type									
Water volume	l	137	193	193	193	340	340	340	340	426	426
Water connections (Victaulic)	in	8	8	8	8	8	8	8	8	8	8
Drain and vent connections (NPT)	in	3/8	3/8	3/8	3/8	3/8	3/8	3/8	3/8	3/8	3/8
Max. water-side operating pressure	kPa	1000	1000	1000	1000	1000	1000	1000	1000	1000	1000

Ⓒ Weight shown is guideline only. Please refer to the unit nameplate

Ⓒ Minimum unit capacity corresponds to a physical state of the unit and is given for indication only. The actual capacity at this stage depends on operating conditions.

Physical data, units for high condensing temperatures

Standard-efficiency units (option 150)

30XW-P / 30XWHP			512	562	712	812	862	1012	1162	1314	1464	1612	1762	
Heating														
Unit + option 150 Full load performances*	HW1	Nominal capacity	kW	600	670	840	910	975	1188	1375	1514	1698	1890	1983
		COP	kW/kW	5,89	5,90	5,72	5,58	5,72	5,61	5,77	5,55	5,40	5,78	5,73
	HW2	Nominal heating capacity	kW	580	646	815	885	950	1147	1322	1465	1648	1834	1929
		COP	kW/kW	4,85	4,86	4,72	4,61	4,75	4,65	4,80	4,62	4,52	4,80	4,79
	HW3	Nominal capacity	kW	561	625	790	862	925	1110	1275	1419	1598	1783	1874
		COP	kW/kW	4,02	4,04	3,92	3,83	3,97	3,86	4,01	3,88	3,81	4,00	4,00
Seasonal energy efficiency**	HW1	SCOP _{30/35°C}	kWh/kWh	6,15	6,22	6,40	6,11	5,99	5,97	6,24	6,18	6,18	6,50	6,21
		ηs heat _{30/35°C}	%	238	241	248	236	231	231	242	239	239	252	240
	HW3	SCOP _{47/55°C}	kWh/kWh	4,78	4,86	4,97	4,76	4,73	4,63	4,88	4,88	4,94	5,07	4,92
		ηs heat _{47/55°C}	%	183	186	191	182	181	177	187	187	189	195	189
		P _{rated}	kW	673	749	947	1030	1106	1330	1531	1701	1915	2133	2243
	Cooling													
Unit + option 150 Full load performances*	CW1	Nominal cooling capacity	kW	510	569	715	770	833	1011	1178	1287	1437	1613	1706
		EER	kW/kW	5,14	5,17	5,02	4,88	5,09	4,98	5,23	4,96	4,84	5,15	5,21
Seasonal energy efficiency**		SEER_{12/7°C} Comfort low temp.	kWh/kWh	6,53	6,68	6,81	6,56	6,45	6,51	6,95	6,76	6,66	7,13	6,90
		ηs cool _{12/7°C}	%	258	264	269	259	255	258	275	267	264	282	273
		SEPR _{12/7°C} Process high temp.	kWh/kWh	6,90	6,93	7,23	6,68	6,38	6,71	6,97	6,88	7,03	7,15	6,63
Integrated Part Load Value	IPLV.SI	kW/kW	6,612	6,804	7,029	6,703	6,782	6,505	6,997	6,946	7,131	7,302	7,308	
Sound levels - unit with option 150														
Sound power level ^①		dB(A)	99	99	102	102	102	102	102	105	105	105	105	
Sound pressure level at 1 m ^②		dB(A)	82	82	84	84	84	83	83	86	86	86	86	
Sound levels - unit with option 150 + option 257^③														
Sound power level ^①		dB(A)	96	96	100	100	100	99	99	103	103	103	103	
Sound pressure level at 1 m ^②		dB(A)	78	78	82	82	82	80	80	84	84	84	84	

* In accordance with standard EN14511-3:2022.
 ** In accordance with standard EN14825:2022, average climate
 HW1 Heating mode conditions: Evaporator entering/leaving water temperature 10°C/7°C, condenser entering/leaving water temperature 30°C/35°C, evaporator and condenser fouling factor 0 m². k/W
 HW2 Heating mode conditions: Evaporator entering/leaving water temperature 10°C/7°C, condenser entering/leaving water temperature 40°C/45°C, evaporator and condenser fouling factor 0 m². k/W
 HW3 Heating mode conditions: Evaporator entering/leaving water temperature 10°C/7°C, condenser entering/leaving water temperature 47°C/55°C, evaporator and condenser fouling factor 0 m². k/W
 CW1 Cooling mode conditions: Evaporator water entering/leaving temperature 12°C/7°C, condenser entering/leaving water temperature 30°C/35°C, evaporator and condenser fouling factor 0 m². K/W
 ηs heat_{30/35°C} & SCOP_{30/35°C} Values calculated in accordance with EN14825:2022
 ηs heat_{47/55°C} & SCOP_{47/55°C} Values calculated in accordance with EN14825:2022
 ηs cool_{12/7°C} & SEER_{12/7°C} **Bold values compliant to Ecodesign regulation: (EU) No 2016/2281 for Comfort application**
 SEPR_{12/7°C} Values calculated in accordance with EN14825:2022
 IPLV.SI Calculations according to standard performances AHRI 551-591 (SI).
 NA Non Authorized for the specific application for CEE market
 ① In dB ref=10² W, (A) weighting. Declared dual number noise emission values in accordance with ISO 4871 (with an associated uncertainty of +/-3dB(A)). Measured in accordance with ISO 9614-1 and certified by Eurovent.
 ② In dB ref 20μPa, (A) weighting. Declared dual number noise emission values in accordance with ISO 4871 (with an associated uncertainty of +/-3dB(A)). For information, calculated from the sound power level Lw(A).
 ③ Option 257 = Low noise level



Eurovent certified values



AHRI certified values
30XW-only

CARRIER participates in the ECP programme for LCP-HP Check ongoing validity of certificate: www.eurovent-certification.com

Physical data, units for high condensing temperatures

30XW-P / 30XWHP		512	562	712	812	862	1012	1162	1314	1464	1612	1762
Dimensions - unit with option 150												
Length	mm	3059	3059	3290	3290	3290	4730	4730	4730	4730	4832	4832
Width	mm	936	936	1105	1105	1105	1039	1039	1202	1202	2174	2174
Height	mm	1743	1743	1970	1970	1970	1997	1997	2071	2071	1585	1585
Operating weight [Ⓒ]	kg	2981	3020	4072	4117	4145	6872	6950	7721	8059	11225	11279
Compressors												
Semi-hermetic 06T screw compressors, 50 r/s												
Circuit A	-	1	1	1	1	1	1	1	1	1	1	1
Circuit B	-	-	-	-	-	-	1	1	1	1	1	1
Refrigerant [Ⓒ]												
R-134a												
Circuit A	kg	130	130	180	175	177	120	120	130	130	240	250
	teqCO ₂	186	186	257	250	253	172	172	186	186	343	358
Circuit B	kg	-	-	-	-	-	120	120	150	130	240	250
	teqCO ₂	-	-	-	-	-	172	172	215	186	343	358
Oil - unit with option 150												
Circuit A	l	32	32	36	36	36	32	32	36	36	36	36
Circuit B	l	-	-	-	-	-	32	32	32	36	36	36
Capacity control												
SmartVu™, electronic expansion valves (EXV)												
Minimum capacity [Ⓒ]	%	30	30	20	20	20	15	15	15	10	10	10
Evaporator												
Multi-pipe flooded type												
Water volume	l	101	101	154	154	154	293	293	321	321	473	473
Water connections (Victaulic)	in	6	6	8	8	8	8	8	8	8	10	10
Drain and vent connections (NPT)	in	3/8	3/8	3/8	3/8	3/8	3/8	3/8	3/8	3/8	3/8	3/8
Max. water-side operating pressure	kPa	1000	1000	1000	1000	1000	1000	1000	1000	1000	1000	1000
Condenser												
Multi-pipe flooded type												
Water volume	l	103	103	148	148	148	316	316	340	340	623	623
Water connections (Victaulic)	in	6	6	8	8	8	8	8	10	10	10	10
Drain and vent connections (NPT)	in	3/8	3/8	3/8	3/8	3/8	3/8	3/8	3/8	3/8	3/8	3/8
Max. water-side operating pressure	kPa	1000	1000	1000	1000	1000	1000	1000	1000	1000	1000	1000

Ⓒ Weight shown is guideline only. Please refer to the unit nameplate

Ⓒ Minimum unit capacity corresponds to a physical state of the unit and is given for indication only. The actual capacity at this stage depends on operating conditions.

Physical data, units for high condensing temperatures

Standard-efficiency 30XW/30XWH units (options 6)

30XW--/30XWH (reference)		254	304	354	402	452	552	602	702	802
Operating weight	kg	2041	2063	2102	2609	2609	2647	2678	3492	3516
Refrigerant charge^①		R-134a								
Circuit A	kg	91	86	84	99	99	99	99	146	135
	teqCO ₂	129730	123552	120463	142085	142085	142085	142085	208494	193050
Circuit B	kg	0	0	0	0	0	0	0	0	0
	teqCO ₂	0	0	0	0	0	0	0	0	0
Evaporator		Single pass, multi-pipe flooded type								
Water volume	l	50	56	61	70	70	70	70	109	109
Water connections (Victaulic)	in	5	5	5	6	6	6	6	6	6
Drain and vent connections (NPT)	in	3/8	3/8	3/8	3/8	3/8	3/8	3/8	3/8	3/8
Max. water-side operating pressure	kPa	1000	1000	1000	1000	1000	1000	1000	1000	1000

30XW--/30XWH (reference)		852	1002	1052	1154	1252	1452	1552	1652	1702
Operating weight	kg	3720	5467	5505	5806	7392	7781	7829	9193	9219
Refrigerant charge^①		R-134a								
Circuit A	kg	171	92	92	113	130	119	113	211	211
	teqCO ₂	244015	131274	131274	162162	185328	169884	162162	301158	301158
Circuit B	kg	0	92	92	113	130	119	113	211	211
	teqCO ₂	0	131274	131274	162162	185328	169884	162162	301158	301730
Evaporator		Single pass, multi-pipe flooded type								
Water volume	l	98	182	182	205	301	301	301	354	354
Water connections (Victaulic)	in	6	6	6	8	8	8	8	8	8
Drain and vent connections (NPT)	in	3/8	3/8	3/8	3/8	3/8	3/8	3/8	3/8	3/8
Max. water-side operating pressure	kPa	1000	1000	1000	1000	1000	1000	1000	1000	1000

① Weights are guidelines only. The refrigerant charge is given on the unit nameplate.

Electrical data, units for high condensing temperatures

Standard-efficiency units (option 150)

30XW--/30XWH-		254	304	354	402	452	552	602	652	702	802
Power circuit											
Nominal power supply	V-ph-Hz	400-3-50									
Voltage range	V	360-440									
Control circuit											
24 V via the built-in transformer											
Nominal start-up current^①											
Circuit A	A	303	388	388	587	587	587	587	772	772	772
Circuit B	A	-	-	-	-	-	-	-	-	-	-
Option 81	A	-	-	-	-	-	-	-	-	-	-
Maximum start-up current^②											
Circuit A	A	303	388	388	587	587	587	587	772	772	772
Circuit B	A	-	-	-	-	-	-	-	-	-	-
Option 81	A	-	-	-	-	-	-	-	-	-	-
Cosine phi											
Nominal ^③		0,79	0,78	0,79	0,83	0,85	0,85	0,85	0,84	0,86	0,87
Maximum ^④		0,88	0,87	0,88	0,90	0,90	0,91	0,91	0,90	0,90	0,90
Total harmonic distortion ^⑤	%	0	0	0	0	0	0	0	0	0	0
Maximum power input^⑥											
Circuit A	kW	97	111	122	156	173	191	191	249	268	286
Circuit B	kW	-	-	-	-	-	-	-	-	-	-
Option 81	kW	-	-	-	-	-	-	-	-	-	-
Nominal current drawn^⑦											
Circuit A	A	95	109	125	150	162	171	171	193	214	232
Circuit B	A	-	-	-	-	-	-	-	-	-	-
Option 81	A	-	-	-	-	-	-	-	-	-	-
Maximum current drawn (Un)^⑧											
Circuit A	A	160	185	200	250	275	300	300	400	430	460
Circuit B	A	-	-	-	-	-	-	-	-	-	-
Option 81	A	-	-	-	-	-	-	-	-	-	-
Maximum current drawn (Un -10%)^⑨											
Circuit A	A	176	206	224	270	300	330	330	419	455	476
Circuit B	A	-	-	-	-	-	-	-	-	-	-
Option 81	A	-	-	-	-	-	-	-	-	-	-

① Instantaneous start-up current (maximum operating current of the smallest compressor(s) + locked rotor current or reduced start-up current of the largest compressor). Values based on standard Eurovent unit operating conditions: evaporator entering/leaving water temp. = 12°C/7°C, condenser entering/leaving water temp. = 30°C/35°C.

② Instantaneous start-up current (maximum operating current of the smallest compressor(s) + locked rotor current or reduced start-up current of the largest compressor). Values obtained at operation with maximum unit power input.

③ Values based on standard Eurovent unit operating conditions: evaporator entering/leaving water temp. = 12°C/7°C, condenser entering/leaving water temp. = 30°C/35°C.

④ Values obtained at operation with maximum unit power input.

⑤ Values obtained at operation with maximum unit power input. Values given on the unit name plate.

Electrical data, units for high condensing temperatures

Standard-efficiency units (option 150)

30XW--/30XWH-		852	1002	1052	1154	1252	1352	1452	1552	1652	1702
Power circuit											
Nominal power supply	V-ph-Hz	400-3-50									
Voltage range	V	360-440									
Control circuit											
24 V via the built-in transformer											
Nominal start-up current^①											
Circuit A	A	772	587	587	587	772	772	772	772	772	772
Circuit B	A	-	587	587	587	587	772	772	772	772	772
Option 81	A	-	757	757	757	943	965	986	1004	1004	1004
Maximum start-up current^②											
Circuit A	A	772	587	587	587	772	772	772	772	772	772
Circuit B	A	-	587	587	587	587	772	772	772	772	772
Option 81	A	-	887	887	887	1072	1172	1202	1232	1004	1232
Cosine phi											
Nominal ^③		0,87	0,85	0,85	0,85	0,86	0,85	0,86	0,87	0,86	0,87
Maximum ^④		0,90	0,90	0,91	0,91	0,91	0,91	0,91	0,91	0,91	0,91
Total harmonic distortion ^⑤	%	0	0	0	0	0	0	0	0	0	0
Maximum power input^⑥											
Circuit A	kW	286	191	191	191	252	252	271	290	290	290
Circuit B	kW	-	173	191	191	191	252	271	290	271	290
Option 81	kW	-	364	382	382	443	504	542	580	562	580
Nominal current drawn^⑥											
Circuit A	A	232	171	171	171	210	210	230	250	250	250
Circuit B	A	-	162	171	171	171	210	230	250	230	250
Option 81	A	-	333	342	342	381	420	460	500	480	500
Maximum current drawn (Un)^⑥											
Circuit A	A	460	300	300	300	400	400	430	460	460	460
Circuit B	A	-	275	300	300	300	400	430	460	430	460
Option 81	A	-	575	600	600	700	800	860	920	890	920
Maximum current drawn (Un -10%)^⑥											
Circuit A	A	476	330	330	330	419	419	455	476	476	476
Circuit B	A	-	300	330	330	330	419	455	476	455	476
Option 81	A	-	630	660	660	749	838	910	952	931	952

① Instantaneous start-up current (maximum operating current of the smallest compressor(s) + locked rotor current or reduced start-up current of the largest compressor). Values based on standard Eurovent unit operating conditions: evaporator entering/leaving water temp. = 12°C/7°C, condenser entering/leaving water temp. = 30°C/35°C.

② Instantaneous start-up current (maximum operating current of the smallest compressor(s) + locked rotor current or reduced start-up current of the largest compressor). Values obtained at operation with maximum unit power input.

③ Values based on standard Eurovent unit operating conditions: evaporator entering/leaving water temp. = 12°C/7°C, condenser entering/leaving water temp. = 30°C/35°C.

④ Values obtained at operation with maximum unit power input.

⑤ Values obtained at operation with maximum unit power input. Values given on the unit name plate.

Electrical data, units for high condensing temperatures

High-efficiency units (option 150)

30XW-P/30XWHP		512	562	712	812	862	1012	1162	1314	1464	1612	1762
Power circuit												
Nominal power supply	V-ph-Hz	400-3-50										
Voltage range	V	360-440										
Control circuit												
24 V via the built-in transformer												
Nominal start-up current^①												
Circuit A	A	587	587	772	772	772	587	587	772	772	772	772
Circuit B	A	-	-	-	-	-	587	587	587	772	772	772
Option 81	A	-	-	-	-	-	749	757	943	965	986	1004
Maximum start-up current^②												
Circuit A	A	587	587	772	772	772	587	587	772	772	772	772
Circuit B	A	-	-	-	-	-	587	587	587	772	772	772
Option 81	A	-	-	-	-	-	862	887	1072	1172	1202	1232
Cosine phi												
Nominal ^③		0,88	0,88	0,84	0,86	0,87	0,87	0,88	0,86	0,85	0,86	0,87
Maximum ^④		0,91	0,92	0,90	0,90	0,90	0,91	0,92	0,91	0,91	0,91	0,91
Total harmonic distortion ^⑤	%	0	0	0	0	0	0	0	0	0	0	0
Maximum power input^⑥												
Circuit A	kW	173	191	252	271	290	173	191	252	252	271	290
Circuit B	kW	-	-	-	-	-	173	191	191	252	271	290
Option 81	kW	-	-	-	-	-	346	382	443	504	542	580
Nominal current drawn^⑦												
Circuit A	A	162	171	210	230	250	162	171	210	210	230	250
Circuit B	A	-	-	-	-	-	162	171	171	210	230	250
Option 81	A	-	-	-	-	-	324	342	381	420	460	500
Maximum current drawn (Un)^⑧												
Circuit A	A	275	300	400	430	460	275	300	400	400	430	460
Circuit B	A	-	-	-	-	-	275	300	300	400	430	460
Option 81	A	-	-	-	-	-	550	600	700	800	860	920
Maximum current drawn (Un -10%)^⑨												
Circuit A	A	300	330	419	455	476	300	330	419	419	455	476
Circuit B	A	-	-	-	-	-	300	330	330	419	455	476
Option 81	A	-	-	-	-	-	600	660	749	838	910	952

① Instantaneous start-up current (maximum operating current of the smallest compressor(s) + locked rotor current or reduced start-up current of the largest compressor). Values based on standard Eurovent unit operating conditions: evaporator entering/leaving water temp. = 12°C/7°C, condenser entering/leaving water temp. = 30°C/35°C.

② Instantaneous start-up current (maximum operating current of the smallest compressor(s) + locked rotor current or reduced start-up current of the largest compressor). Values obtained at operation with maximum unit power input.

③ Values based on standard Eurovent unit operating conditions: evaporator entering/leaving water temp. = 12°C/7°C, condenser entering/leaving water temp. = 30°C/35°C.

④ Values obtained at operation with maximum unit power input.

⑤ Values obtained at operation with maximum unit power input. Values given on the unit name plate.

Dimensions/clearances

30XW--/30XWH- 254-852
30XW-P/30XWHP 512-862

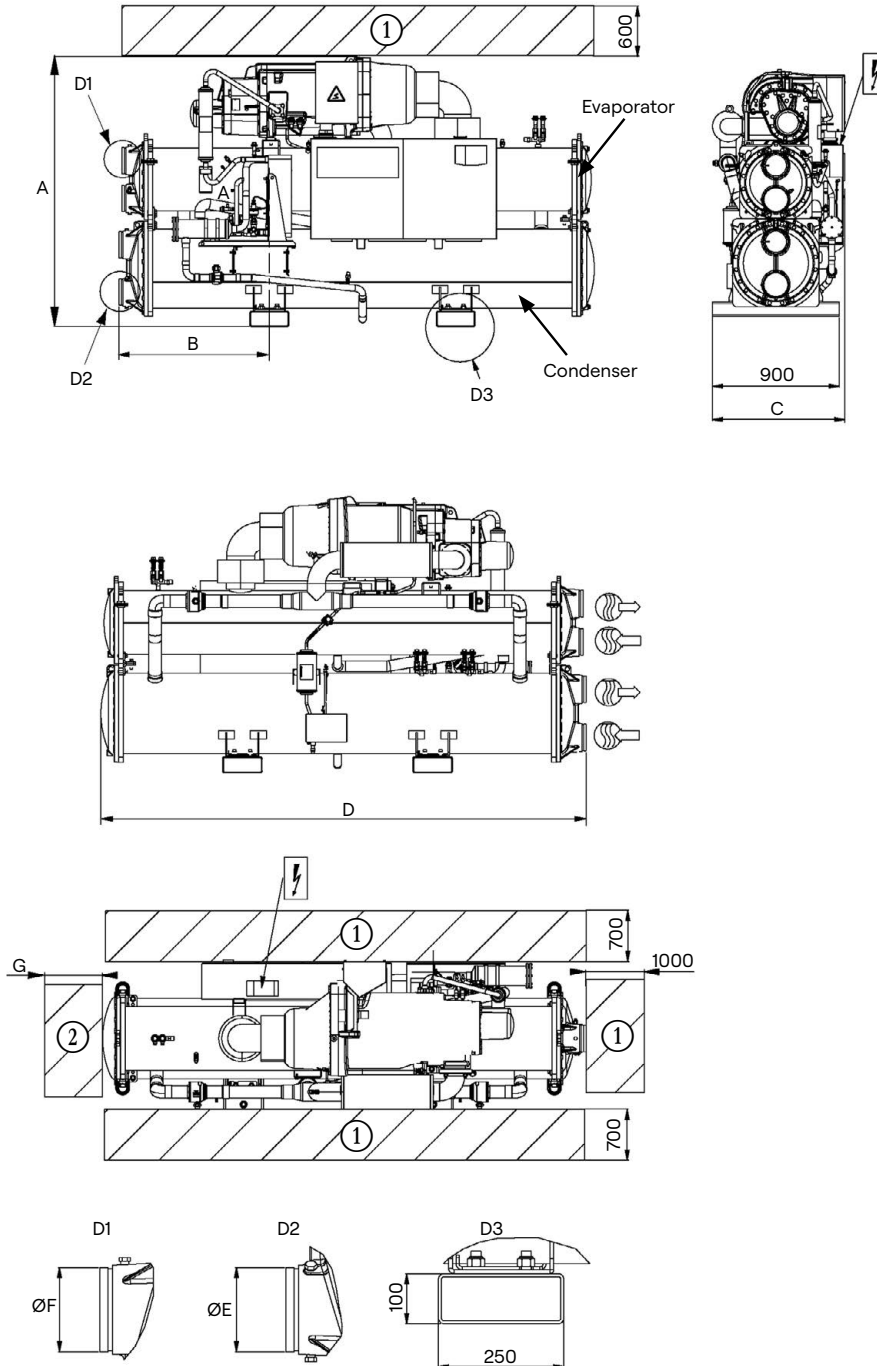

Key:

All dimensions are given in mm.

- ① Required clearance for maintenance
- ② Recommended clearance for tube removal
- ← Water inlet
- Water outlet
-))) Air outlet – do not obstruct
- ⚡ Power supply connection

- Option 6 has same dimensions as option 150.
- Option 20 (IP44) has same dimensions as option 150 on units 652, 712, 802, 852, 862. Option 20 has same dimensions as standard on the other units.

NOTE: Drawings are not contractually binding. Before designing an installation, consult the certified dimensional drawings, available on request.

Dimensions/clearances

30XW--/30XWH- 254-852
30XW-P/30XWHP 512-862

	Dimensions in mm						
	A	B	C	D	E	F	G
Standard-efficiency units 30XW--/30XWH-							
254	1567	800	928	2724	141,3	141,3	2600
304	1567	800	928	2724	141,3	141,3	2600
354	1567	800	928	2724	141,3	141,3	2600
402	1693	810	936	2742	141,3	141,3	2600
452	1693	810	936	2742	141,3	141,3	2600
552	1693	810	936	2742	141,3	141,3	2600
602	1693	810	936	2742	141,3	141,3	2600
652	1848	968	1044	3059	168,3	168,3	2800
702	1848	968	1044	3059	168,3	168,3	2800
802	1848	968	1044	3059	168,3	168,3	2800
852	1898	828	1044	2780	219,1	168,3	2600
High-efficiency units 30XW-P/30XWHP							
512	1743	968	936	3059	168,3	168,3	2800
562	1743	968	936	3059	168,3	168,3	2800
712	1950	1083	1065	3290	219,1	219,1	3100
812	1950	1083	1070	3290	219,1	219,1	3100
862	1950	1083	1070	3290	219,1	219,1	3100
Standard-efficiency units 30XW--/30XWH- (option 150)							
254	1567	800	928	2724	141,3	141,3	2600
304	1567	800	928	2724	141,3	141,3	2600
354	1567	800	928	2724	141,3	141,3	2600
402	1693	810	936	2742	141,3	141,3	2600
452	1693	810	936	2742	141,3	141,3	2600
552	1693	810	936	2742	141,3	141,3	2600
602	1693	810	936	2742	141,3	141,3	2600
652	1868	968	1090	3059	168,3	168,3	2800
702	1868	968	1090	3059	168,3	168,3	2800
802	1868	968	1090	3059	168,3	168,3	2800
852	1920	828	1090	2780	168,3	219,1	2600
High-efficiency units 30XW-P/30XWHP (option 150)							
512	1743	968	936	3059	168,3	168,3	2800
562	1743	968	936	3059	168,3	168,3	2800
712	1970	1083	1105	3290	219,1	219,1	3100
812	1970	1083	1105	3290	219,1	219,1	3100
862	1970	1083	1105	3290	219,1	219,1	3100

Dimensions/clearances

30XW--/30XWH- 1002-1552
30XW-P/30XWHP 1012-1464

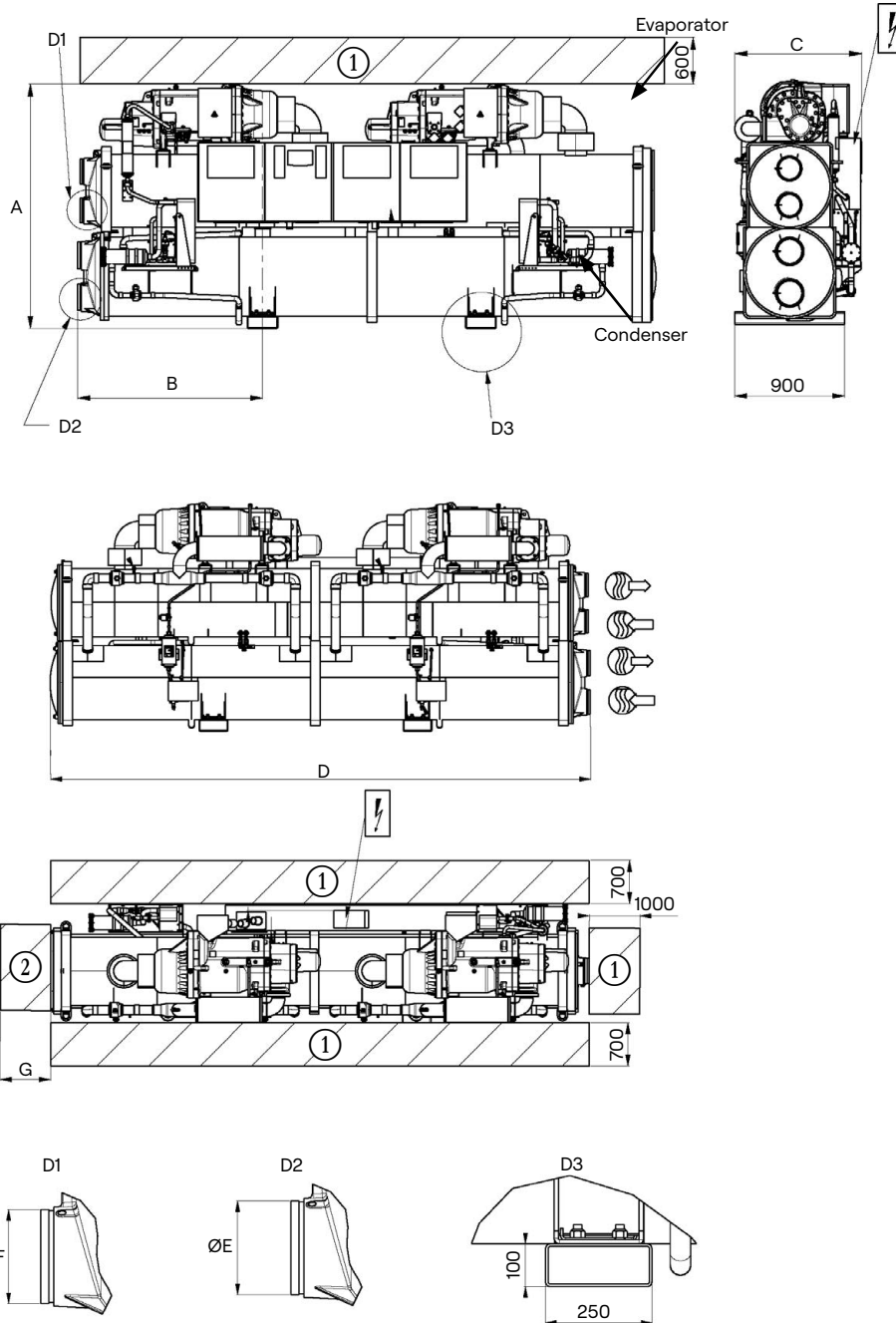

Key:

All dimensions are given in mm.

- ① Required clearance for maintenance
- ② Recommended clearance for tube removal
- ← Water inlet
- Water outlet
-))) Air outlet – do not obstruct
- ⚡ Power supply connection

- Option 6 has same dimensions as option 150.
- Option 20 (IP44) has same dimensions as option 150 on units 652, 712, 802, 852, 862. Option 20 has same dimensions as standard on the other units.

NOTE: Drawings are not contractually binding. Before designing an installation, consult the certified dimensional drawings, available on request.

Dimensions/clearances

30XW--/30XWH- 1002-1552 30XW-P/30XWHP 1012-1464

	Dimensions in mm						
	A	B	C	D	E	F	G
Standard-efficiency units 30XW--/30XWH-							
1002	1870	950	1036	4025	219,1	168,3	3800
1052	1870	950	1036	4025	219,1	168,3	3800
1152	1925	950	1036	4025	219,1	219,1	3800
1252	2051	1512	1162	4730	219,1	219,1	4500
1352	2051	1512	1162	4730	219,1	219,1	4500
1452	2051	1512	1162	4730	219,1	219,1	4500
1552	2051	1512	1162	4730	219,1	219,1	4500
High-efficiency units 30XW-P/30XWHP							
1012	1997	1512	1039	4730	219,1	219,1	4500
1162	1997	1512	1039	4730	219,1	219,1	4500
1314	2051	1512	1162	4730	219,1	219,1	4500
1464	2051	1512	1162	4730	219,1	219,1	4500
Standard-efficiency units 30XW--/30XWH- (option 150)							
1002	1870	950	1036	4025	219,1	168,3	3800
1052	1870	950	1036	4025	219,1	168,3	3800
1154	2925	950	1036	4025	219,1	219,1	3800
1252	2071	1512	1202	4730	219,1	219,1	4500
1352	2071	1512	1202	4730	219,1	219,1	4500
1452	2071	1512	1202	4730	219,1	219,1	4500
1552	2071	1512	1202	4730	219,1	219,1	4500
High-efficiency units 30XW-P/30XWHP (option 150)							
1012	1997	1512	1039	4730	219,1	219,1	4500
1162	1997	1512	1039	4730	219,1	219,1	4500
1314	2071	1512	1202	4730	219,1	219,1	4500
1464	2071	1512	1202	4730	219,1	219,1	4500

Dimensions/clearances

30XW--/30XWH- 1652-1702
30XW-P/30XWHP 1612-1762

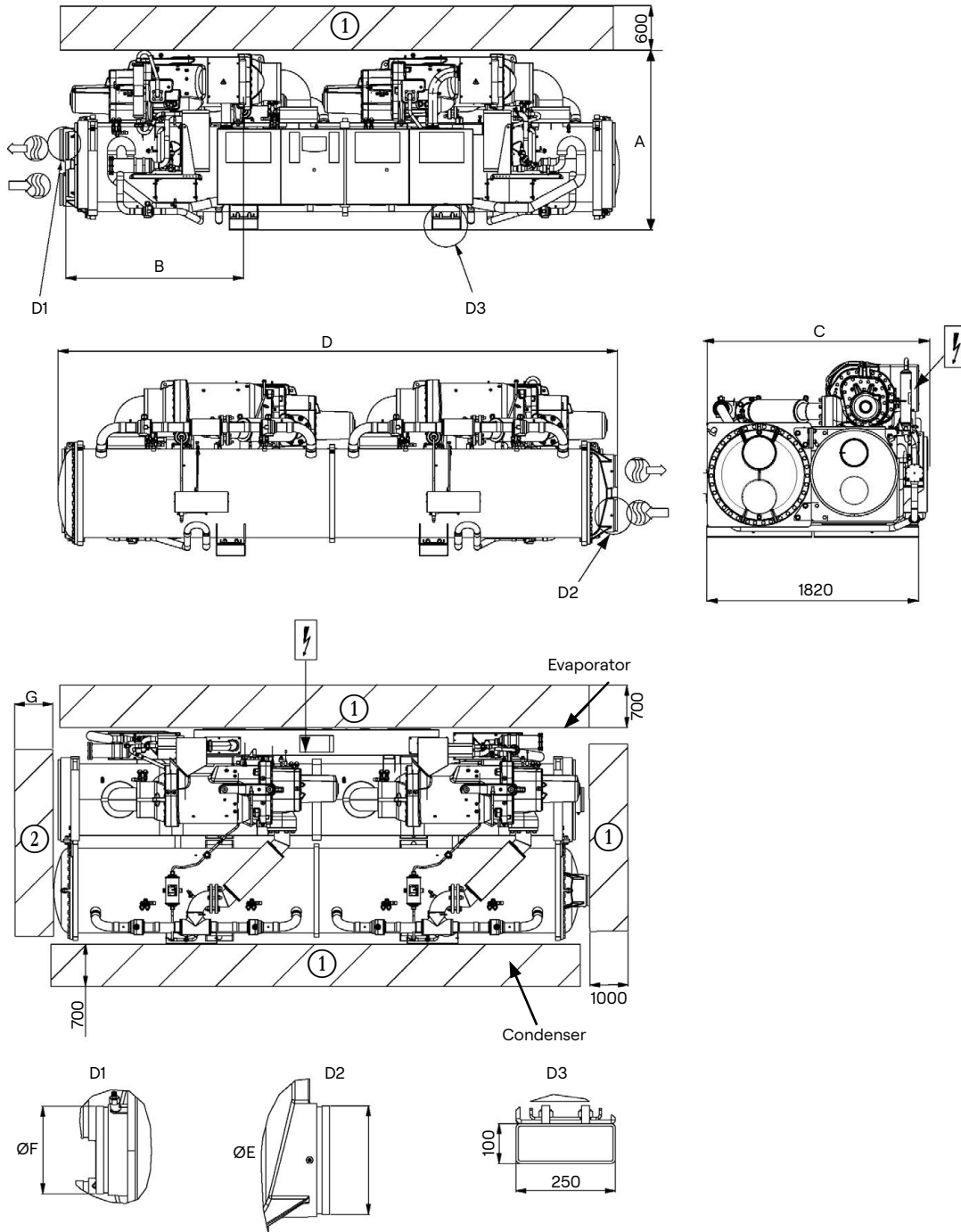

Key:

All dimensions are given in mm.

- ① Required clearance for maintenance
- ② Recommended clearance for tube removal
- ← Water inlet
- Water outlet
-))) Air outlet – do not obstruct
- ⚡ Power supply connection

- Option 6 has same dimensions as option 150.
- Option 20 (IP44) has same dimensions as option 150 on units 652, 712, 802, 852, 862. Option 20 has same dimensions as standard on the other units.

NOTE: Drawings are not contractually binding. Before designing an installation, consult the certified dimensional drawings, available on request.

Dimensions/clearances

30XW--/30XWH- 1652-1702
30XW-P/30XWHP 1612-1762

	Dimensions in mm						
	A	B	C	D	E	F	G
Standard-efficiency units 30XW--/30XWH-							
1652	1515	1568	1902	4790	219,1	219,1	4500
1702	1515	1568	1902	4790	219,1	219,1	4500
High-efficiency units 30XW-P/30XWHP							
1612	1562	1591	2129	4832	273,1	273,1	4600
1762	1562	1591	2129	4832	273,1	273,1	4600
Standard-efficiency units 30XW--/30XWH- (option 150)							
1652	1535	1568	1947	4790	219,1	219,1	4500
1702	1535	1568	1947	4790	219,1	219,1	4500
High-efficiency units 30XW-P/30XWHP (option 150)							
1612	1585	1591	2174	4832	273,1	273,1	4600
1762	1585	1591	2174	4832	273,1	273,1	4600