

AQUASNAP®



30WI

Heat pumps and liquid coolers with water cooled condenser

Cooling and heating application
High energy efficiency
Compact design
Low sound level
Broad field of application

Cooling capacity:
200-400 kW

Heating capacity:
230-500 kW



CARRIER participates in the ECP programme for LCP-HP Check ongoing validity of certificate: www.eurovent-certification.com

The new generation of AquaSnap 30WI water cooled heat pumps and water chillers offers an optimal solution for all heating process or cooling applications.

These units are designed to be installed in machine rooms that are protected against freezing temperatures and inclement weather.

The new range has been optimised to use ozone-friendly HFC R410A refrigerant. The use of this refrigerant guarantees compliance with the most demanding requirements for environmental protection and increased seasonal energy efficiency.



Range

AquaSnap 30WI

Cooling-only or heating-only models with water-cooled condenser.

Acoustic configuration:

- a - STANDARD version.
- b - LOW NOISE version. Compressor casing.
- c - VERY LOW NOISE version. Casing with compressor sound insulation.

Description

AquaSnap series 30WI units are packaged machines supplied as standard with the following components:

- SCROLL hermetic compressors.
- Chilled water evaporator with brazed plates.
- Hot water condenser with brazed plates.
- Electrical power and remote control cabinet:
 - 400V-3ph-50Hz general electrical power supply (+10%/-10%) + earth.
 - Transformer fitted as standard on the machine for supplying the remote control circuit with 230V-1ph-50Hz.
- 30WI Control electronic control module.

The AquaSnap 30WI range complies with the following European standards and directives:

- Machinery directive 2006/42/EC.
- Electromagnetic compatibility directive 2004/108/EC.
- EMC immunity and emissions EN 61800-3 'C3'.
- Low voltage directive 2006/95/EC.
- RoHS 2011/65/EU.
- Pressure equipment directive (PED) 97/23/EC.
- Machinery directive EN 60-204 -1.

Description of the main components

■ Compressors:

- Hermetic SCROLL type.
- Built-in electric motor cooled by intake gases.
- Motor protected by internal winding thermostat.
- Placed on anti-vibration mounts.

■ Evaporator:

- Brazed plate exchanger.
- Stainless steel plates (AISI 316).
- Plate patterns optimised for high efficiency.
- Armaflex thermal insulation.

■ Condenser:

- Brazed plate exchanger.
- Stainless steel plates (AISI 316).
- Plate patterns optimised for high efficiency.

■ Refrigerating accessories:

- Dehumidifier filters with rechargeable cartridges.
- Hygroscopic sight glasses.
- Solenoid valves on refrigerant lines.
- Electronic expansion valves.

■ Control and safety instruments:

- High and low pressure sensors.
- High pressure safety valves.
- Water temperature control sensors.
- Evaporator frost protection sensor.
- Factory-assembled evaporator water flow controller.

■ Electrical box:

- IP 23.
- 400V-3Ph-50 Hz power supply + Earth (+10%/-10%).
- Main safety switch with handle on front.
- Control circuit transformer.
- Circuit breaker for compressor motor.
- Compressor motor switches.
- 30WI Control microprocessor-controlled electronic control module.
- Wire numbering.
- Marking of the main electrical components.
- RAL 7035.

■ 30WI Control electronic control module:

The electronic control module performs the following main functions:

- Regulation of the chilled or hot water temperature.
- Regulation of the water temperature based on the outdoor temperature (water law).
- Regulation for low temperature energy storage.
- Second setpoint management.
- Complete management of compressors with start-up sequence, metering and runtime balancing.
- Self-adjusting and proactive functions with adjustment of parameters on drift control.
- In-series staged capacity-reduction system on compressors based on cooling and heating demands.
- Management of compressor short cycle protection.
- Management of the machine operation limit according to outdoor temperature.
- Operating and fault status diagnostics.
- Management of a fault memory allowing a log of the last 20 incidents to be accessed, with operating readings taken when the fault occurs.
- Lead/lag management of the two machines in parallel with runtime balancing and automatic changeover if a fault occurs on one machine.
- Machine time schedule.
- Display and access to the operating parameters via a multilingual LCD screen with 4 lines of 24 characters.

■ Remote management:

30WI Control is equipped as standard with an RS485 serial port offering a range of remote management, monitoring and diagnostic options via the communication bus.

Several contacts are available as standard, enabling the AquaSnap 30WI to be controlled remotely by wired link:

- Automatic operation control: when this contact is open, the machine stops.
- Setpoint 1/setpoint 2 selector: when this contact is closed, a second cooling setpoint is activated (energy storage mode, for example).
- Heating/cooling mode selector: this input switches from one operating mode to another. Contact closed = heating mode.

Contact open = cooling mode.

- Setpoint adjustable via 4-20 mA signal: this input is used to adjust the setpoint in heating or cooling mode.
- Compressor load shedding: closing the contact(s) concerned allows the power or refrigerating consumption of the machine to be limited by stopping one or more compressors.
- Water pump 1 and 2 control: these outputs control the switches for one or two water pumps.
- Fault reporting: this contact indicates the presence of a major fault which has caused one or both refrigerating circuits to stop.

■ Capacity control:

In-series staged power control system on the compressors:

- 4 stages for 700 V to 1200 V models.

■ Casing:

Casing made from RAL 7035 painted panels.

Options

Options	No.	Description	Advantages	Use
Soft Starter	25	Electronic starter on each compressor	Reduced start-up current	0700-1200
Lead/lag operation	58	Unit equipped with supplementary water outlet temperature sensor kit to be fieldinstalled allowing lead/lag operation of two units connected in parallel	Optimised operation of two units connected in parrallele operation with operating time equalisation	0700-1200
Condenser insulation	86	Thermal condenser insulation	Minimizes thermal dispersions condenser side (key option for heat pump or heat recovery applications) and allows compliancy with special installation criteria (hot parts insulated)	0700-1200
Compressor suction valve	92	Valve installed on the compressor suction side to isolate it in the refrigerant circuit	Simplified service and maintenance	0700-1200
Lon gateway	148D	Two-directional communication board complying with Lon Talk protocol	Connects the unit by communication bus to a building management system	0700-1200
Bacnet over IP	149	Two-directional high-speed communication using BACnet protocol over Ethernet network (IP)	Easy and high-speed connection by ethernet line to a building management system. Allows access to multiple unit parameters	0700-1200
Dry contact board	156C	Feedback board on the potential-free contact for the main statuses and faults	Simple feedback of the diagnostics and unit state	0700-1200
Phase controller	159B	Phase controller on the power	Reinforced protection of the compressors by monitoring rotation, the absence and asymmetry of the phases, and the over- or under-voltage of the electricity network	0700-1200
Compliance with Russian regulations	199	EAC certification	Conformance with Russian regulations	0700-1200
Low noise level	257	Compressor sound enclosure	Reduced sound emissions	0700-1200
Very low sound level	258	Enhanced sound insulation of main noise sources (Material classified CD0S2 fire class according to Euroclass 13-501).	6 dB(A) quieter than standard . Refer to the physical data table for detailed values	0700-1200
Welded evaporator connection kit	266	Victaulic piping connections with welded joints	Easy installation	0700-1200
Welded condenser water connection kit	267	Victaulic piping connections with welded joints	Easy installation	0700-1200
Electric energy meter	294	MID certified electric energy meter (compliant with directive 2004/22/EC). Display of energy consumption, instantaneous (U, V, I) and cumulative (kWh), on the SmartVu™ interface	Permits the acquisition, (remote) monitoring and billing of energy used.	0700-1200
External temperature sensor	312	External temperature sensor control for using weather compensation	Allow to adjust set point using weather compensation and define autorisation operation mode to external temperature	0700-1200
Compliance with Morocco regulation	327	Specifics documents according Morrocco regulation	Conformance with Morocco regulations	0700-1200

Technical specifications

30WI		700 V	800 V	900 V	1000 V	1100 V	1200 V		
Heating									
Standard unit Seasonal energy efficiency**	HA1	SCOP _{30/35°C}	kW/kW	5,30	5,53	5,45	5,47	5,43	5,49
		ηs heat _{30/35°C}	%	204	213	210	211	209	212
		P_{rated}	kW	246	293	335	384	419	463
Cooling									
Standard unit Full load performances*	CA1	Net cooling capacity	kW	203	242	278	320	348	382
		Net power input	kW	49	56	64	71	79	86
		EER	kW/kW	4,18	4,32	4,33	4,5	4,42	4,42
Standard unit Seasonal energy efficiency**		SEPR _{-2/-8°C} Process medium temp ***	kWh/kWh	3,04	3,08	3,09	3,04	3,08	3,11
Standard unit Seasonal energy efficiency**		SEER _{12/7°C} Comfort Low temp.	kW/kW	4,66	4,96	4,92	4,96	4,91	4,92
Standard unit		Lw / Lp ^①	dB(A)	89/57	90/58	90/58	89/57	90/58	91/59
Unit + Low Noise option		Lw / Lp ^①	dB(A)	84/52	85/53	85/53	86/54	87/55	88/56
Unit + Xtra Low Noise		Lw / Lp ^①	dB(A)	79/47	80/48	80/48	80/48	81/49	82/50
Refrigerating circuit									
Refrigerant (GWP)		R410 (GWP=2088 - AR4)							
Number		2							
Refrigerant circuit 1		kg	13,5	15,5	16,4	17	19,7	21,3	
Refrigerant circuit 2		kg	14	15	16,4	17,2	19,7	21,3	
Tonne of CO ₂ equivalent		TCO ₂ Eq	57,42	63,68	68,49	71,41	82,27	88,95	

Outputs in accordance with EUROVENT standard EN 14511 conditions.

* In accordance with standard EN14511-3:2022.

** In accordance with standard EN14825:2022, average climate.

*** With EG 30%.

HA1 Heating mode conditions: Water heat exchanger water entering/leaving temperature 30°C/35°C, outside air temperature tdb/twb = 7°C db/6°C wb, evaporator fouling factor 0 m². k/W.

CA1 Cooling mode conditions: evaporator water inlet/outlet temperature 12 °C/7 °C, outdoor air temperature 35 °C, evaporator fouling factor 0 m². k/W.

ηs heat_{30/35°C} & **SCOP**_{30/35°C} **Values in bold comply with Ecodesign Regulation (EU) No. 813/2013 for Heating applications.**

SEER_{12/7°C} Values calculated according to EN14825:2022.

SEPR_{-2/-8°C} **Values in bold comply with Ecodesign Regulation (EU) No. 2015/1095 for Process application .**

① **Lw** : overall power level in accordance with standard ISO3744.

Lp : overall pressure level at 10 metres in a free field calculated using the formula Lp=LW-10logS.



CARRIER participates in the ECP programme for LCP-HP Check ongoing validity of certificate: www.eurovent-certification.com

Eurovent certified values

Technical specifications

30WI		700 V	800 V	900 V	1000 V	1100 V	1200 V
Compressor							
Type		Hermetic scroll (- 2900 rpm)					
Number		4	4	4	4	4	4
Start-up mode		Direct in line in series					
	Number of stages	6	4	6	4	6	4
Capacity control	%	100-78-71-50-28-21-0	100-75-50-25-0	100-78-71-50-28-21-0	100-75-50-25-0	100-78-71-50-28-21-0	100-75-50-25-0
Type of oil for R410A		Polyolester POE					
Oil load per circuit	l	6,7+6,7	6,7+6,7	6,7+6,7	6,7+6,7	6,7+7,2	7,2+7,2
Evaporator							
Type/ Number		Braze-plate heat exchanger/1					
Water capacity	l	20	23	26	29	32	37
Victaulic connection	Ø	DN100	DN100	DN100	DN125	DN125	DN125
Max. pressure, water end	bar	10 bar					
Min/max water flow	m ³ /h	22/70	26/81	29/92	33/105	35/113	38/124
Water-cooled condenser							
Type/ Number		Braze-plate heat exchanger/1					
Water capacity	l	23	26	29	32	37	40
Victaulic connection	Ø	DN100	DN100	DN100	DN125	DN125	DN125
Max. pressure, water end	bar	10 bar					
Min/max water flow	m ³ /h	19/64	22/74	25/84	28/95	31/103	33/112
Dimensions							
Length	mm	2099	2099	2099	2099	2099	2099
Width	mm	996					
Height	mm	1869	1869	1869	1869	1869	1869
Weight							
Weight (empty)	kg	1044	1156	1189	1312	1363	1425
Weight in operation	kg	1088	1205	1246	1378	1436	1510
Max. storage temperature	°C	+50°C					

Electrical specifications

30WI		700 V	800 V	900 V	1000 V	1100 V	1200 V
COMPRESSOR							
Voltage	V	400V - 3Ph - 50Hz (+10/- 10%)					
Maximum nominal current	A	140	160	182	205	218	232
Starting current^①	A	316	334	391	414	480	494
Starting current with Soft Start option^①	A	230	248	287	310	352	366
REMOTE CONTROL AUXILIARY CIRCUIT							
Voltage	V	230V - 1Ph - 50Hz (+10/- 10%)					
Maximum nominal current	A	0,8	0,8	0,8	0,8	0,8	0,8
Transformer capacity	VA	160	160	160	160	160	160
Machine protection rating		IP 21					

- ① Starting current of largest compressor + maximum current of other compressors under full load.
Cable selection nominal current = sum of maximum nominal currents in above tables.

Dimensions

700 V to 1200 V models

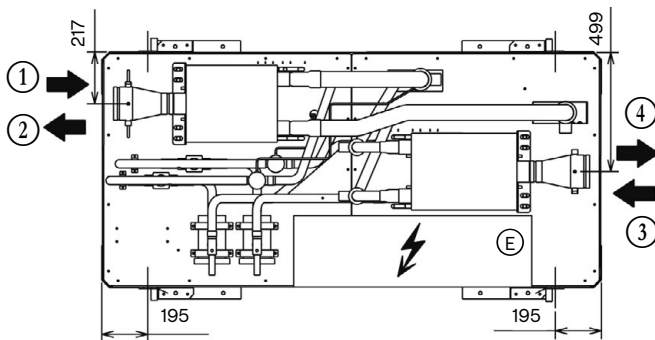
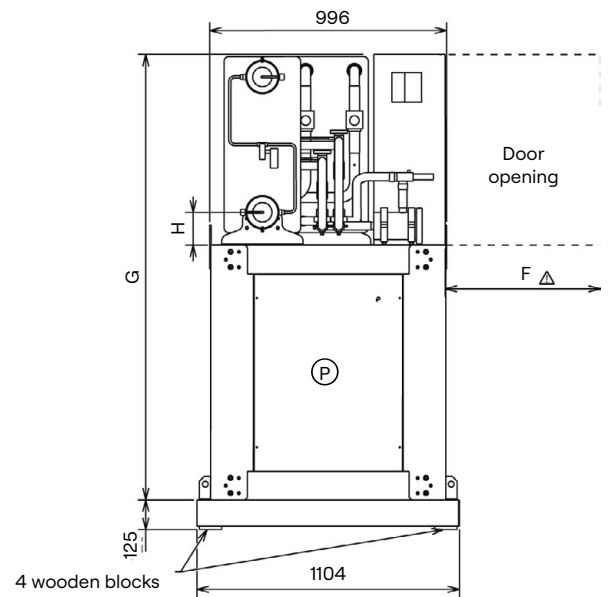
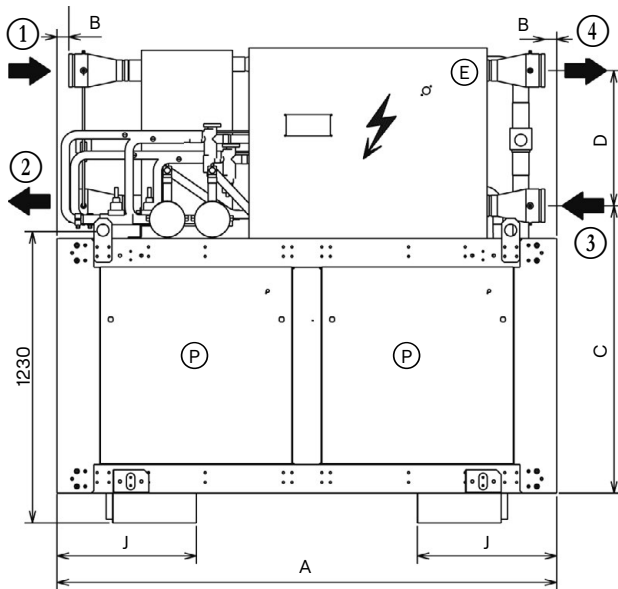

(E) Electrical connection on the side.

(P) Noise insulation panels option.

Models	Dimensions (mm)								Chilled water		Hot water		Weight (kg)	
	A	B	C	D	F	G	H	J	Inlet 1	Outlet 2	Inlet 3	Outlet 4	Empty	In operation
700 V	2099	49	1207	568	1000	1869	137	585	VICTAULIC DN 100				1044	1088
800 V	2099	49	1207	568	1000	1869	137	585					1156	1205
900 V	2099	49	1207	568	1000	1869	137	585					1189	1246
1000 V	2099	49	1207	568	1000	1869	137	585	VICTAULIC DN 125				1312	1378
1100 V	2099	49	1207	568	1000	1869	137	585					1363	1436
1200 V	2099	49	1207	568	1000	1869	137	585					1425	1510