

AQUAFORCE®

30XW-PZE/ 30XWHPZE

Water-cooled screw
chillers
Water-sourced screw heat
pumps

Nominal cooling capacity:
271-1110 kW

Nominal heating capacity:
322-1297 kW



CARRIER participates in the ECP programme for
LCP-HP Check ongoing validity of certificate:
www.eurovent-certification.com

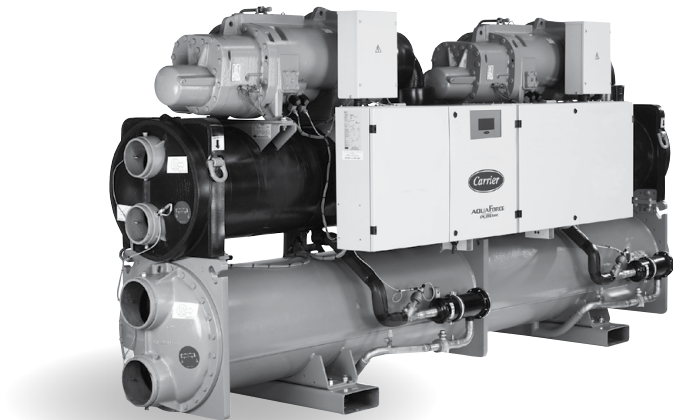

Low energy consumption
High reliability
Safe Design
Easy and fast installation
Minimised operating sound
levels
Environmental care

The 30XW-PZE liquid chillers are the premium solution for industrial and commercial applications where installers, consultants and building owners require optimal performances and maximum quality.

The 30XW-PZE liquid chillers are designed to meet current and future requirements in terms of energy efficiency, flexibility of use and compactness. They use the most reliable technologies available today:

- Twin-rotor screw compressors with a variable capacity valve.
- R-1234ze refrigerant or R-515B.
- Flooded heat exchangers that are mechanically cleanable.
- Carrier SmartVu™ control with color touch screen user interface that includes 10 languages.

The AquaForce PUREtec range is splitted into two versions:

- 30XW-PZE for air conditioning and refrigeration applications.
- 30XWHPZE for heating applications.

As standard, the unit can provide an evaporator leaving temperature down to 3,3°C, and when operating as a heat pump, it can deliver up to 55°C (70°C optional) on the condenser side.



Customer Benefits

Low energy consumption

- 30XW-PZE range is compliant with EU Eco-design Minimum Efficiency Performance Standards (MEPS) in cooling that apply from January 2021.
- SEER 12/7°C up to 7.6 and SEPR 12/7°C up to 9.3.
- 30XWHPZE range is compliant with EU Eco-design Minimum Efficiency Performance Standards (MEPS) in heating that apply from September 2015.
- COP of up to 6.7 and SCOP up to 7.2.
- The high energy efficiency is reached through:
 - Twin-rotor screw compressor equipped with a high-efficiency motor and a variable capacity valve that permits exact matching of the cooling capacity to the load.
 - Flooded multi-pipe heat exchangers for increased heat exchange efficiency.
 - Electronic expansion device permitting operation at a lower condensing pressure and improved utilisation of the evaporator heat exchange surface.
 - Economizer system with electronic expansion device for increased cooling capacity.

Low operating sound levels

- Standard unit features include:
 - Silencers on the compressors discharge line.
 - Silencers on the economiser return line.
 - Acoustic insulation on the components that are most subjected to radiated noise.
 - Option 257 further reduces the global unit sound level.

Easy and fast installation

- Compact design:
 - The 30XW units are designed to offer the most compact dimensions on the market.
 - With a width of approximately 1 m up to 1300 kW the units can pass through standard door openings and only require minimum floor space in the plant room.

Compact, accessible unit - side view - sizes up to 1300 KW

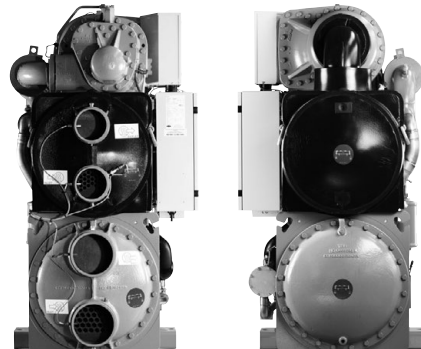

- Simplified electrical connections:
 - Main disconnect switch with high trip capacity.
 - Transformer to supply the integrated control circuit (400/24 V).
- Simplified hydraulic connections:
 - Victaulic connections on the evaporator and condenser.
 - Practical reference marks for entering and leaving water connections.
 - Possibility to reverse the heat exchanger water inlet and outlet at the factory.
 - Possibility to modify the number of heat exchanger passes.
- Fast commissioning:
 - Systematic factory operation test before shipment.
 - Quick-test function for step-by-step verification of the instruments, expansion devices and compressors.

Customer Benefits

Environmental care



- R-1234ze long-term refrigerant solution:
 - HFO refrigerant with nearly zero global warming potential (GWP < 1) and zero ozone depletion potential (ODP = 0).
 - Not impacted by the HFC phase-down plan in Europe (79% HFC reduction in EU member states at 2030 horizon).
 - Compliant with refrigerant regulation in Switzerland that bans the use of HFC refrigerant in large capacity air-conditioning equipment.
- Leak-tight refrigerant circuit:
 - Reduction of leaks as no capillary tubes and flare connections are used.
 - Verification of pressure transducers and temperature sensors without transferring refrigerant charge.
 - Discharge line shut-off valve and liquid line service valve for simplified maintenance.

High reliability and easy servicing

- The 30XW units offer increased global performance as well as Carrier's acclaimed product quality and reliability.
- Major components are selected and tested with R-1234ze and R-515B refrigerant to minimize failures possibility, as well as many design choices have been taken in this perspective.
- Non flammable use possible when selecting option 330, Low GWP A1 R-515 Refrigerant.
- Screw compressors:
 - Industrial-type screw compressors with oversized bearings and motor cooled by suction gas.
 - All compressor components are easily accessible on site minimising down-time.
- Refrigerant circuit:

Two independent refrigerant circuits (from 1000 kW upwards); the second one automatically takes over, if the first one develops a fault, maintaining partial cooling under all circumstances.
- Evaporator:

Electronic paddle-free flow switch. Auto-setting according to cooler size and fluid type.
- Auto-adaptive control:
 - Control algorithm prevents excessive compressor cycling (Carrier patent).
 - Automatic compressor unloading in case of abnormally high condensing pressure.
- Exceptional endurance tests:
 - Partnerships with specialised laboratories and use of limit simulation tools (finite element calculation) for the design of critical components.
 - Transport simulation test in the laboratory on a vibrating table and then on an endurance circuit (based on a military standard).

Safe Design

- Specific polyol ester oil qualified by Carrier for using with HFO-1234ze or R-515B to guarantee and maintain reliable bearing lubrication.
- Specific compressor gaskets compatible with HFO-1234ze or R-515B, tested and validated by Carrier.
- New relief valves designed for operation with HFO-1234ze or R-515B.
- Specific electrical box with increased tightness and integrated blower that maintains positive air pressure to avoid any risk of ignition when using R-1234ze refrigerant.
- No need of ducted electrical cabinet fresh air supply when using option 330 - LOW GWP A1 R-515B refrigerant.
- New control algorithms.
- Specific documentation that contains all the installation, operation, maintenance and safety Instructions.

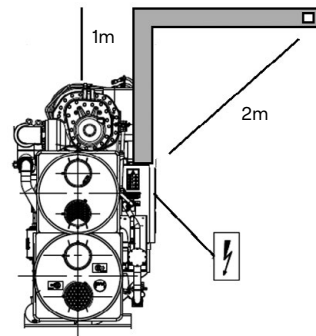

Technical insights

SmartVu™ Control

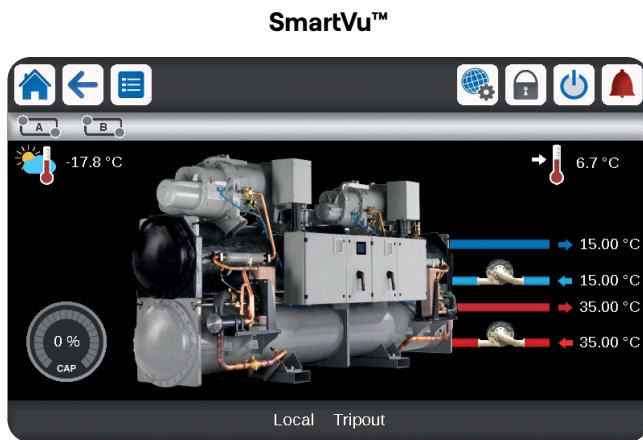

- New innovative smart control features:
 - An intuitive and user-friendly, coloured, 7" interface.
 - 10 languages available on choice: DE, EN, ES, FR, IT, NL, PT, TR, TU + one additional customer choice.
 - Screen-shots with concise and clear information in local languages.
 - Complete menu, customised for different users (end user, service personnel and Carrier-factory technicians).
 - Setpoint offset based on the outside air temperature.
 - Safe operation and unit setting: Password protection ensures that unauthorised people cannot modify any advanced parameters.
 - Simple and "smart" intelligence uses data collection from the constant monitoring of all machine parameters to optimise unit operation.
 - Night-mode: Cooling capacity management for reduced noise level.
 - With hydraulic module: Water pressure display and water flow rate calculation.
- Energy management:
 - Internal time schedule clock controls chiller on/off times and operation at a second set-point.
 - The DCT (Data Collection Tool) records the alarms history to simplify and facilitate service operations.
- Maintenance functions:
 - F-Gas regulation leak check reminder alert.
 - Maintenance alert can be configured to days, months or hours of operation.
- Advanced communication features:
 - Easy and high-speed communication technology over Ethernet (IP) to a centralised building management system.
 - Access to multiple unit parameters.

Remote Management (Standard)

- Units with SmartVu™ control can be easily accessed from the internet, using a PC with an Ethernet connection. This makes remote control quick and easy and offers significant advantages for service operations.
- Aquaforce with Greenspeed® Intelligence is equipped with an RS485 serial port that offers multiple remote control, monitoring and diagnostic possibilities. When networked with other Carrier equipment through the CCN (Carrier Comfort Network - proprietary protocol), all components form a HVAC system fully-integrated and balanced through one of the Carrier's network system products, like the Chiller System manager or the Plant System manager (optional).
- The 30XWZE/30XWPZE also communicates with other building management systems via optional communication gateways (BACnet, LON or JBus).
- The following commands/visualisations are possible from remote connection:
 - Start/Stop of the machine.
 - Dual set-point management: Through a dedicated contact is possible to activate a second set-point (example, unoccupied mode).
 - Demand limit setting: To limit the maximum chiller capacity to a predefined value.
 - Water pump control: These outputs control the contactors of one/two evaporator water pumps.
 - Water pumps changeover (only with hydraulic module options): These contacts are used to detect a water pump operation fault and automatically change over to the other pump.
 - Operation visualisation: Indication if the unit is operating or if it is in stand-by (no cooling load).
 - Alarm visualisation.

Technical insights

Remote management (EMM option)

- The Energy management module (E) offers extended remote control possibilities.
- Room temperature: Permits set-point reset based on the building indoor air temperature (if Carrier thermostats are installed).
- Set-point reset: Allows reset of the cooling set-point based on a 4-20 mA or 0-10 V signal.
- Demand limit: Permits limitation of the maximum chiller capacity based on 0-10 V signal.
- Demand limit 1 and 2: Closing of these contacts limits the maximum chiller capacity to two predefined values.
- User safety: This contact can be used for any customer safety loop; opening the contact generates a specific alarm.
- Ice storage end: When ice storage has finished, this input permits return to the second set-point (unoccupied mode).
- Time schedule override: Closing of this contact cancels the programmed time schedule.
- Out of service: This signal indicates that the chiller is completely out of service.
- Chiller capacity: This analogue output (0-10 V) gives an immediate indication of the chiller capacity.
- Alert indication: This volt-free contact indicates the necessity to carry out a maintenance operation or the presence of a minor fault.
- Compressors running status: Set of outputs (as many as the compressors number) indicating which compressors are running.

06T screw compressor

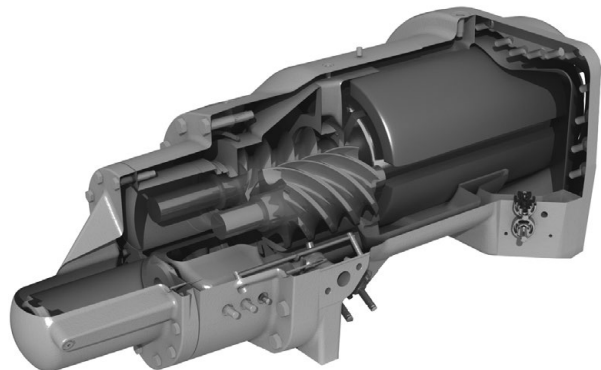

The Carrier 06T screw compressor designed for operation with HFO-1234ze and R-515B refrigerant benefits from Carrier's long experience in the development of twin-rotor screw compressors. The compressor is equipped with bearings with oversized rollers, oil pressure lubricated for reliable and durable operation, even at maximum load.

A variable control valve controlled by the oil pressure permits infinitely variable cooling capacity. This system allows optimal adjustment of the compressor cooling capacity and ensures exceptionally high stability of the chilled water leaving temperature.

Among the other advantages: if a fault occurs e.g. if the condenser is fouled or at very high water temperature, the compressor does not switch off, but continues operation with a reduced capacity (unloaded mode).

The silencer in the discharge line considerably reduces discharge gas pulsations for much quieter operation.

The condenser includes an oil separator that minimises the amount of oil in circulation in the refrigerant circuit and re-directs it to the compressor function.

Digit number

1	2	3	4	5	6	7	8	9	1	1	1	1	1	1	1	1	1
3	0	X	W	-	P	Z	E	0	3	0	1	B	0	0	0	1	-

- Legend:**
- Digit 1 to 4 : Water-cooled chiller with screw compressor
 - Digit 5 : Application type, - = Cooling, H = Heating
 - Digit 6 : Efficiency, - = standard, P = premium
 - Digit 7 & 8 : Unit using R1234ze refrigerant
 - Digit 9 to 12 : Model number based on cooling capacity in kW
 - Digit 13 : Index for major product modification (visible impact for customer)
 - Digit 14 to 17 : Counter used to generate a one time product code
 - Digit 18 : Not used

Options

Options	N°	Description	Advantages	Use
Light-brine solution, down to -3°C	8	Implementation of new algorithms of control to allow chilled brine solution production down to -3°C when ethylene glycol is used (0°C with propylene glycol)	Matches with most application requirements for ground-sourced heat pumps and fits with many industrial processes requirements	301-1101
Lead/lag operation	58	Unit equipped with supplementary water outlet temperature sensor kit to be field-installed allowing Lead/lag operation of two units connected in parallel	Optimised operation of two units connected in parrallele operation with operating time equalisation	301-1101
Single power connection point	81	Unit power connection via one main supply connection	Quick and easy installation	801-1101
Evap. pump power/control circuit	84	Unit equipped with an electrical power and control circuit for one pump evaporator side	Quick and easy installation: the control of fixed speed pumps is embedded in the unit control	301-1001
Evap. dual pumps power/control circuit	84D	Unit equipped with an electrical power and control circuit for two pumps evaporator side	Quick and easy installation: the control of fixed speed pumps is embedded in the unit control	301-1001
Cond. pump power/control circuit	84R	Unit equipped with an electrical power and control circuit for one pump condenser side	Quick and easy installation: the control of fixed speed pumps is embedded in the unit control	301-1001
Condenser insulation	86	Thermal condenser insulation	Minimizes thermal dispersions condenser side (key option for heat pump or heat recovery applications) and allows compliancy with special installation criteria (hot parts insulated)	301-1101
Service valve set	92	Liquid line valve (evaporator inlet) and compressor suction line valve	Allow isolation of various refrigerant circuit components for simplified service and maintenance	301-1101
Evaporator with one pass less	100C	Evaporator with one pass on the water side. Evaporator inlet and outlet on opposite sides.	Easy to install, depending on site. Reduced pressure drops	301-1101
Condenser with one pass less	102C	Condenser with one pass on the water side. Condenser inlet and outlet on opposite sides.	Easy to install, depending on site. Reduced pressure drops	301-1101
21 bar evaporator	104	Reinforced evaporator for extension of the maximum water-side service pressure to 21 bar (standard 10 bar)	Covers applications with a high water column evaporator side (typically high buildings)	301-1101
21 bar condenser	104A	Reinforced condenser for extension of the maximum water-side service pressure to 21 bar (standard 10 bar)	Covers applications with a high water column condenser side (typically high buildings)	301-1101

Options

Options	N°	Description	Advantages	Use
Reversed evaporator water connections	107	Evaporator with reversed water inlet/outlet	Easy installation on sites with specific requirements	301-1101
Reversed condenser water connections	107A	Condenser with reversed water inlet/outlet	Easy installation on sites with specific requirements	301-1101
Lon gateway	148D	Two-directional communication board complying with Lon Talk protocol	Connects the unit by communication bus to a building management system	301-1101
Bacnet over IP	149	Two-directional high-speed communication using BACnet protocol over Ethernet network (IP)	Easy and high-speed connection by ethernet line to a building management system. Allows access to multiple unit parameters	301-1101
Modbus over IP and RS485	149B	Bi-directional high-speed communication using Modbus protocol over Ethernet network (IP)	Easy and high-speed connection by ethernet line to a building management system. Allows access to multiple unit parameters	301-1101
High condensing temperature	150	Optimized compressor for operation at high condensing temperature	Increased condenser leaving water temperature up to 70°C. Allows applications with high condensing temperature (heat pumps, installations with not generously sized dry coolers or more generally, installations with dry coolers in hot climate). NOTE: to ensure control of the condenser leaving water temperature, this option must be fitted with 30XWH units.	301-1101
Condensing temperature limitation	150B	Limitation of the maximum condenser leaving water temperature to 45°C	Reduced maximum power input and current absorption: power cables and protection elements can therefore be downsized	301-1101
Control for low cond. temperature systems	152	Output signal (0-10 V) to control the condenser water inlet valve	Simple installation: for applications with cold water at condenser inlet (ex. ground-source, groundwater-source, superficial water-source applications) the signal permits to control a 2 or 3-way valve to maintain condenser water temperature (and so condensing pressure) at acceptable values	301-1101
Dry cooler control	154	Adaptation of the control box for communication with the dry cooler via a bus. For dry cooler need to select the cabinet with option control cabinet manage by the chiller control	Easy system management, extended control capabilities of a remote dry cooler	301-1101
Energy Management Module	156	EMM Control board with additional inputs/outputs. See Energy Management Module option chapter	Extended remote control capabilities (Set-point reset, ice storage end, demand limits, boiler on/off command...)	301-1101
SmartVu™ control, 7" user interface	158A	SmartVu™ control supplied with a 7 inch colour touch screen user interface	Enhanced ease of use.	301-1101

Options

Options	N°	Description	Advantages	Use
Dual relief valves on 3-way valve	194	Three-way valve upstream of dual relief valves on the shell and tubes evaporator	Valve replacement and inspection facilitated without refrigerant loss. Comforms to European standard EN378/BGVD4	301-1101
Compliance with Swiss regulations	197	Additional tests on the water heat exchangers: supply (additional of PED documents) supplementary certificates and test certifications	Conformance with Swiss regulations	301-1101
Compliance with Australian regulations	200	Unit approved to Australian code	Conformance with Australian regulations	301-1101
Low noise level	257	Evaporator sound insulation	3 dB(A) quieter than standard unit	401-1101
Welded evaporator connection kit	266	Victaulic piping connections with welded joints	Easy installation	301-1101
Welded condenser water connection kit	267	Victaulic piping connections with welded joints	Easy installation	301-1101
Flanged evaporator water connection kit	268	Victaulic piping connections with flanged joints	Easy installation	301-1101
Flanged condenser water connection kit	269	Victaulic piping connections with flanged joints	Easy installation	301-1101
Thermal compressor insulation	271	The compressor is covered with a thermal insulation layer	Prevents air humidity to condensate on the compressor surface	301-1101
ABOUND HVAC Performance (Connectivity embedded)	298A	Factory mounted connectivity device including 4G Modem & Antenna and access to Digital Services during warranty period.	Complete real time unit monitoring with web access to data and alarms. Enables more comprehensive Digital Service offers and service plans.	301-1101
ABOUND HVAC Performance (Connectivity embedded) – Non DSO	298B	Factory mounted connectivity device including 4G Modem & antenna. Subscription to Digital Services purchased through Carrier Service.	Enables real time unit monitoring with more comprehensive Digital Service offers and service plans.	301-1101
Free-cooling dry cooler control	313	Control & connections to a Free Cooling Dry cooler 09PE or 09VE fitted with option FC control box	Easy system management, Extended control capabilities to a dry cooler used in Free Cooling mode	301-1101
Low GWP A1 R-515B refrigerant	330	Unit delivered with R-515B refrigerant charge (A1, GWP 299)	Reduced CO ₂ footprint (GWP < 300) A1 safety class Reduced installed cost in technical room	301-1101

Physical data, standard units

30XW-PZE / 30XWHPZE			301	401	451	551	601	651	801	901	1001	1101	
Heating													
Standard unit Full load performances*	HW1	Nominal capacity	kW	322	448	509	657	698	758	916	1012	1168	1297
		COP	kW/kW	6,12	6,55	6,47	6,63	6,48	6,47	6,52	6,49	6,50	6,30
	HW2	Nominal capacity	kW	318	439	500	646	686	741	900	991	1146	1271
		COP	kW/kW	4,66	4,94	4,88	4,99	4,85	4,89	4,95	4,92	4,95	4,80
	HW3	Nominal capacity	kW	315	433	494	638	678	725	890	976	1129	1251
		COP	kW/kW	3,65	3,82	3,80	3,84	3,74	3,80	3,83	3,82	3,86	3,73
Standard unit Seasonal energy efficiency**	HW1	SCOP _{30/35°C}	kW/kW	6,20	6,74	6,81	6,48	6,53	6,57	6,79	6,97	6,88	6,51
		η _{s heat} _{30/35°C}	%	240	262	264	251	253	255	264	271	267	252
	HW3	SCOP _{47/55°C}	kW/kW	4,43	5,04	4,99	4,49	4,60	4,73	5,07	5,09	4,95	4,62
		η _{s heat} _{47/55°C}	%	169	194	192	171	176	181	195	195	190	177
		P _{rated}	kW	411	540	615	795	845	908	1108	1218	1408	1562
Cooling													
Standard unit Full load performances*	CW1	Nominal capacity	kW	271	385	435	561	595	648	783	874	1001	1111
		EER	kW/kW	5,28	5,75	5,66	5,80	5,66	5,69	5,74	5,83	5,80	5,65
	CW2	Nominal capacity	kW	375	538	610	764	813	880	1086	1220	1383	1522
		EER	kW/kW	8,00	8,15	7,99	8,55	8,17	8,33	8,10	8,13	8,27	8,13
Standard unit Seasonal energy efficiency**		SEER_{12/7°C} Comfort low temp.	kWh/kWh	6,43	7,03	7,35	6,54	6,65	6,97	7,10	7,59	7,61	7,14
		η _{s cool} _{12/7°C}	%	254	278	291	259	263	276	281	301	301	283
		SEPR_{12/7°C} Process high temp.	kWh/kWh	9,27	8,76	8,75	9,36	8,78	8,84	8,76	9,06	9,26	9,19

* In accordance with standard EN14511-3:2022
 ** In accordance with standard EN14825:2022, average climate
 HW1 Heating mode conditions: Evaporator entering/leaving water temperature 10°C/7°C, condenser entering/leaving water temperature 30°C/35°C, evaporator and condenser fouling factor 0 m². k/W
 HW2 Heating mode conditions: Evaporator entering/leaving water temperature 10°C/7°C, condenser entering/leaving water temperature 40°C/45°C, evaporator and condenser fouling factor 0 m². k/W
 HW3 Heating mode conditions: Evaporator entering/leaving water temperature 10°C/7°C, condenser entering/leaving water temperature 47°C/55°C, evaporator and condenser fouling factor 0 m². k/W
 CW1 Cooling mode conditions: Evaporator water entering/leaving temperature 12°C/7°C, condenser entering/leaving water temperature 30°C/35°C, evaporator and condenser fouling factor 0 m². K/W
 CW2 Cooling mode conditions: Evaporator water entering/leaving temperature 23°C/18°C, condenser entering/leaving water temperature 30°C/35°C, evaporator and condenser fouling factor 0 m². K/W
 η_{s heat}_{30/35°C} & SCOP_{30/35°C} Values calculated in accordance with EN14825:2022
 η_{s heat}_{47/55°C} & SCOP_{47/55°C} Values calculated in accordance with EN14825:2022
 η_{s cool}_{12/7°C} & SEER_{12/7°C} **Bold values compliant to Ecodesign regulation: (EU) No 2016/2281 for Comfort application**
 SEPR_{12/7°C} **Bold values compliant to Ecodesign regulation: (EU) No 2016/2281 for Process application**



Eurovent certified values

CARRIER participates in the ECP programme for LCP-HP Check ongoing validity of certificate: www.eurovent-certification.com

Physical data, standard units

30XW-PZE / 30XWHPZE		301	401	451	551	601	651	801	901	1001	1101
Sound levels - standard unit											
Sound power level ^①	dB(A)	93	97	97	97	97	97	100	100	100	100
Sound pressure level at 1 m ^②	dB(A)	76	80	80	79	79	79	81	81	81	81
Sound levels - standard unit + option 257^③											
Sound power level ^①	dB(A)	-	94	94	94	94	94	97	97	97	97
Sound pressure level at 1 m ^②	dB(A)	-	76	76	76	76	76	78	78	78	78
Dimensions - standard unit											
Length	mm	2724	3059	3059	3290	3290	3290	4730	4730	4730	4730
Width	mm	928	936	936	1069	1069	1069	1039	1039	1162	1162
Height	mm	1567	1743	1743	1950	1950	1950	1997	1997	2051	2051
Operating weight^④	kg	2157	3050	3050	3942	3977	3995	6932	7010	7665	7875
Compressors											
Semi-hermetic 06T screw compressors, 50 r/s											
Circuit A	-	1	1	1	1	1	1	1	1	1	1
Circuit B	-	-	-	-	-	-	-	1	1	1	1
Refrigerant - standard unit											
R-1234ze											
Circuit A	kg	78	130	130	180	175	170	120	120	130	130
	teq CO ₂	0,5	0,9	0,9	1,3	1,2	1,2	0,8	0,8	0,9	0,9
Circuit B	kg	-	-	-	-	-	-	120	120	150	130
	teq CO ₂	-	-	-	-	-	-	0,8	0,8	1,1	0,9
Refrigerant - option 330											
R-515B											
Circuit A	kg	79	132	132	183	178	173	122	122	132	132
	teq CO ₂	23,1	38,7	38,7	53,6	52,2	50,7	35,7	35,7	38,7	38,7
Circuit B	kg	-	-	-	-	-	-	122	122	152	132
	teq CO ₂	-	-	-	-	-	-	35,7	35,7	44,5	38,7
Oil - standard unit											
HATCOL-4496											
Circuit A	l	20	20	20	25	25	25	20	20	25	25
Circuit B	l	-	-	-	-	-	-	20	20	20	25
Capacity control											
SmartVu™, electronic expansion valves (EXV)											
Minimum capacity	%	30	30	30	15	15	30	30	30	15	15
Evaporator											
Multi-pipe flooded type											
Water volume	l	61	101	101	154	154	154	293	293	321	321
Water connections (Victaulic)	in	5	6	6	8	8	8	8	8	8	8
Drain and vent connections (NPT)	in	3/8	3/8	3/8	3/8	3/8	3/8	3/8	3/8	3/8	3/8
Max. water-side operating pressure	kPa	1000	1000	1000	1000	1000	1000	1000	1000	1000	1000
Condenser											
Multi-pipe flooded type											
Water volume	l	55	103	103	148	148	148	316	316	340	340
Water connections (Victaulic)	in	5	6	6	8	8	8	8	8	8	8
Drain and vent connections (NPT)	in	3/8	3/8	3/8	3/8	3/8	3/8	3/8	3/8	3/8	3/8
Max. water-side operating pressure	kPa	1000	1000	1000	1000	1000	1000	1000	1000	1000	1000

① In dB ref=10² W, (A) weighting. Declared dualnumber noise emission values in accordance with ISO 4871 (with an associated uncertainty of +/-3dB(A)). Measured in accordance with ISO 9614-1 and certified by Eurovent.

② In dB ref 20μPa, (A) weighting. Declared dualnumber noise emission values in accordance with ISO 4871 (with an associated uncertainty of +/-3dB(A)). For information, calculated from the sound power level Lw(A).

③ Option 257 = Low noise level

④ Weight shown is guideline only. Please refer to the unit nameplate

Electrical data, standard units

30XW-PZE / 30XWHPZE		301	401	451	551	601	651	801	901	1001	1101
Power circuit											
Nom. power supply	V-ph-Hz	400-3-50									
Voltage range	V	360-440									
Control circuit											
24 V via the built-in transformer											
Nominal start-up current^①											
Circuit A	A	303	414	414	587	587	587	414	414	587	587
Circuit B	A	-	-	-	-	-	-	414	414	414	587
Option 81	A	-	-	-	-	-	-	529	543	716	751
Maximum start-up current^②											
Circuit A	A	303	414	414	587	587	587	414	414	587	587
Circuit B	A	-	-	-	-	-	-	414	414	414	587
Option 81	A	-	-	-	-	-	-	597	621	794	855
Cosine phi											
Nominal ^③		0,79	0,86	0,87	0,85	0,87	0,89	0,86	0,87	0,85	0,85
Maximum ^④		0,90	0,90	0,90	0,90	0,90	0,90	0,90	0,90	0,90	0,90
Total harmonic distortion ^⑤	%	Closed to 0% (negligible)									
Maximum power input^⑤											
Circuit A	kW	86	112	126	148	165	174	112	126	148	148
Circuit B	kW	-	-	-	-	-	-	112	126	126	148
Option 81	kW	-	-	-	-	-	-	224	252	274	296
Nominal current drawn^⑤											
Circuit A	A	91	115	129	164	177	194	115	129	164	164
Circuit B	A	-	-	-	-	-	-	115	129	129	164
Option 81	A	-	-	-	-	-	-	230	258	293	328
Maximum current drawn (Un)^⑤											
Circuit A	A	140	180	205	240	268	282	180	205	240	240
Circuit B	A	-	-	-	-	-	-	180	205	205	240
Option 81	A	-	-	-	-	-	-	360	410	445	480
Maximum current drawn (Un -10%)^⑤											
Circuit A	A	153	196	223	261	292	307	196	223	261	261
Circuit B	A	-	-	-	-	-	-	196	223	223	261
Option 81	A	-	-	-	-	-	-	392	446	484	522
Maximum power input with option 150B^⑤											
Circuit A	kW	76	97	110	129	146	153	97	110	129	129
Circuit B	kW	-	-	-	-	-	-	97	110	110	129
Option 81	kW	-	-	-	-	-	-	195	220	239	258
Maximum current drawn (Un) with option 150B^⑤											
Circuit A	A	123	158	179	209	237	249	158	179	209	209
Circuit B	A	-	-	-	-	-	-	158	179	179	209
Option 81	A	-	-	-	-	-	-	316	358	388	418

① Instantaneous start-up current (maximum operating current of the smallest compressor(s) + locked rotor current or reduced start-up current of the largest compressor). Values obtained at standard Eurovent conditions: evaporator entering/leaving water temp. = 12°C/7°C, condenser entering/leaving water temp. = 30°C/35°C.

② Instantaneous start-up current (maximum operating current of the smallest compressor(s) + locked rotor current or reduced start-up current of the largest compressor). Values obtained at operation with maximum unit power input.

③ Values obtained at standard Eurovent conditions: evaporator entering/leaving water temp. = 12°C/7°C, condenser entering/leaving water temp. = 30°C/35°C.

④ Values obtained at operation with maximum unit power input.

⑤ Values obtained at operation with maximum unit power input. Values given on the unit nameplate.

Physical data, units for high condensing temperatures (option 150)

30XW-ZE / 30XWHZE		301	401	451	551	601	651	801	901	1001	1101			
Heating														
Unit + option 150 Full load performances*	HW1	Nominal capacity	kW	319	462	516	642	697	771	912	1057	1159	1297	
		COP	kW/kW	5,61	6,01	6,05	5,83	5,71	5,93	5,76	5,98	5,73	5,61	
	HW2	Nominal capacity	kW	310	446	498	623	678	753	880	1018	1123	1260	
		COP	kW/kW	4,59	4,93	4,97	4,8	4,7	4,91	4,74	4,93	4,74	4,66	
	HW3	Nominal capacity	kW	302	433	482	605	661	734	853	983	1089	1223	
		COP	kW/kW	3,78	4,05	4,09	3,95	3,88	4,06	3,89	4,06	3,94	3,88	
	HW4	Nominal capacity	kW	293	420	467	585	645	715	828	950	1057	1186	
		COP	kW/kW	3,07	3,29	3,32	3,21	3,16	3,29	3,15	3,29	3,21	3,18	
Unit + option 150 Seasonal energy efficiency**	HW1	SCOP _{30/35°C}	kW/kW	5,8	6,18	6,25	6,38	6,28	6,29	6,21	6,31	6,26	6,3	
		η _{s heat} _{30/35°C}	%	224	239	242	247	243	244	240	244	242	244	
	HW3	SCOP _{47/55°C}	kW/kW	4,7	4,77	4,83	4,86	4,84	4,9	4,77	4,87	4,84	4,89	
		η _{s heat} _{47/55°C}	%	180	183	185	186	186	188	183	187	186	187	
			P _{rated}	kW	421	544	607	761	829	922	1073	1240	1371	1539
	Cooling													
Unit + option 150 Full load performances*	CW1	Nominal capacity	kW	269	393	439	547	591	656	776	910	985	1101	
		EER	kW/kW	4,86	5,2	5,27	5,07	4,95	5,18	5,05	5,34	5,03	4,94	
	CW2	Nominal capacity	kW	352	538	605	725	782	877	1057	1251	1332	1466	
		EER	kW/kW	5,58	6,44	6,4	6,24	6,12	6,42	6,23	6,45	6,16	6,06	
Unit + option 150 Seasonal energy efficiency**	SEER_{12/7°C} Comfort low temp.		kWh/kWh	6,24	6,57	6,65	6,52	6,57	6,5	6,67	6,8	6,63	6,6	
	η_{s cool}_{12/7°C}		%	247	260	263	258	260	257	264	269	262	261	
	SEPR_{12/7°C} Process high temp.		kWh/kWh	6,80	7,01	7,07	7,39	6,97	6,99	6,96	7,23	7,11	7,30	

* In accordance with standard EN14511-3:2022

** In accordance with standard EN14825:2022, average climate

HW1 Heating mode conditions: Evaporator entering/leaving water temperature 10°C/7°C, condenser entering/leaving water temperature 30°C/35°C, evaporator and condenser fouling factor 0 m². k/W

HW2 Heating mode conditions: Evaporator entering/leaving water temperature 10°C/7°C, condenser entering/leaving water temperature 40°C/45°C, evaporator and condenser fouling factor 0 m². k/W

HW3 Heating mode conditions: Evaporator entering/leaving water temperature 10°C/7°C, condenser entering/leaving water temperature 47°C/55°C, evaporator and condenser fouling factor 0 m². k/W

HW4 Heating mode conditions: Evaporator entering/leaving water temperature 10°C/7°C, condenser entering/leaving water temperature 55°C/65°C, evaporator and condenser fouling factor 0 m². k/W

CW1 Cooling mode conditions: Evaporator water entering/leaving temperature 12°C/7°C, outside air temperature 35°C, evaporator fouling factor 0 m².K/W

CW2 Cooling mode conditions: Evaporator water entering/leaving temperature 23°C/18°C, outside air temperature 35°C, evaporator fouling factor 0 m².K/W

η_{s heat}_{30/35°C} & SCOP_{30/35°C} Values calculated in accordance with EN14825:2022

η_{s heat}_{47/55°C} & SCOP_{47/55°C} Values calculated in accordance with EN14825:2022

η_{s cool}_{12/7°C} & SEER_{12/7°C} **Bold values compliant to Ecodesign regulation: (EU) No 2016/2281 for Comfort application**

SEPR_{12/7°C} Values calculated in accordance with EN14825:2022



Eurovent certified values

CARRIER participates in the ECP programme for LCP-HP. Check ongoing validity of certificate: www.eurovent-certification.com

Physical data, units for high condensing temperatures (option 150)

30XW-ZE / 30XWHZE		301	401	451	551	601	651	801	901	1001	1101
Sound levels - unit with option 150											
Sound power level ^①	dB(A)	93	97	97	100	100	100	100	100	103	103
Sound pressure level at 1 m ^②	dB(A)	76	80	80	82	82	82	81	81	84	84
Sound levels - standard unit + option 257^③											
Sound power level ^①	dB(A)	-	94	94	98	98	98	97	97	101	101
Sound pressure level at 1 m ^②	dB(A)	-	76	76	80	80	80	78	78	82	82
Operating weight^④	kg	2157	3050	3050	4102	4147	4175	6932	7010	7844	8182
Compressors											
Semi-hermetic O6T screw compressors, 50 r/s											
Circuit A	-	1	1	1	1	1	1	1	1	1	1
Circuit B	-	-	-	-	-	-	-	1	1	1	1
Refrigerant - unit with option 150											
R-1234ze											
Circuit A	kg	78	130	130	180	175	170	120	120	130	130
	teq CO ₂	0,5	0,9	0,9	1,3	1,2	1,2	0,8	0,8	0,9	0,9
Circuit B	kg	-	-	-	-	-	-	120	120	150	130
	teq CO ₂	-	-	-	-	-	-	0,8	0,8	1,1	0,9
Refrigerant - option 330											
R-515B											
Circuit A	kg	79	132	132	183	178	173	122	122	132	132
	teq CO ₂	23,1	38,7	38,7	53,6	52,2	50,7	35,7	35,7	38,7	38,7
Circuit B	kg	-	-	-	-	-	-	122	122	152	132
	teq CO ₂	-	-	-	-	-	-	35,7	35,7	44,5	38,7
Oil - unit with option 150											
HATCOL-4496											
Circuit A	l	20	20	20	25	25	25	20	20	25	25
Circuit B	l	-	-	-	-	-	-	20	20	20	25
Capacity control											
SmartVu™, electronic expansion valves (EXV)											
Minimum capacity	%	30	30	30	20	20	25	15	15	15	10
Evaporator											
Multi-pipe flooded type											
Water volume	l	61	101	101	154	154	154	293	293	321	321
Water connections (Victaulic)	in	5	6	6	8	8	8	8	8	8	8
Drain and vent connections (NPT)	in	3/8	3/8	3/8	3/8	3/8	3/8	3/8	3/8	3/8	3/8
Max. water-side operating pressure	kPa	1000	1000	1000	1000	1000	1000	1000	1000	1000	1000
Condenser											
Multi-pipe flooded type											
Water volume	l	55	103	103	148	148	148	316	316	340	340
Water connections (Victaulic)	in	5	6	6	8	8	8	8	8	10	10
Drain and vent connections (NPT)	in	3/8	3/8	3/8	3/8	3/8	3/8	3/8	3/8	3/8	3/8
Max. water-side operating pressure	kPa	1000	1000	1000	1000	1000	1000	1000	1000	1000	1000

① In dB ref=10¹² W, (A) weighting. Declared dualnumber noise emission values in accordance with ISO 4871 (with an associated uncertainty of +/-3dB(A)). Measured in accordance with ISO 9614-1 and certified by Eurovent.

② In dB ref 20µPa, (A) weighting. Declared dualnumber noise emission values in accordance with ISO 4871 (with an associated uncertainty of +/-3dB(A)). For information, calculated from the sound power level Lw(A).

③ Option 257 = Low noise level

④ Weight shown is guideline only. Please refer to the unit nameplate

Electrical data, units for high condensing temperatures (option 150)

30XW-PZE / 30XWHPZE		301	401	451	551	601	651	801	901	1001	1101
Power circuit											
Nominal power supply	V-ph-Hz	400-3-50									
Voltage range	V	360-440									
Control circuit											
24 V via the built-in transformer											
Nominal start-up current^①											
Circuit A	A	388	587	587	629	629	629	587	587	629	629
Circuit B	A	-	-	-	-	-	-	587	587	587	629
Option 81	A	-	-	-	-	-	-	712	725	767	815
Maximum start-up current^②											
Circuit A	A	388	587	587	629	629	629	587	587	629	629
Circuit B	A	-	-	-	-	-	-	587	587	587	629
Option 81	A	-	-	-	-	-	-	833	860	902	972
Cosine phi											
Cosine phi nominal ^③		0,75	0,80	0,81	0,80	0,81	0,83	0,80	0,81	0,80	0,80
Cosine phi maximum ^④		0,90	0,90	0,90	0,89	0,89	0,89	0,90	0,90	0,89	0,89
Total harmonic distortion ^⑤	%	Closed to 0% (negligible)									
Maximum power input^⑥											
Circuit A	kW	107	144	158	202	219	228	144	158	202	202
Circuit B	kW	-	-	-	-	-	-	144	158	158	202
Option 81	kW	-	-	-	-	-	-	288	317	360	404
Nominal current drawn^⑦											
Circuit A	A	102	125	138	186	197	213	125	138	186	186
Circuit B	A	-	-	-	-	-	-	125	138	138	186
Option 81	A	-	-	-	-	-	-	250	276	324	372
Maximum current drawn (Un)^⑧											
Circuit A	A	174	234	257	328	356	371	234	257	328	328
Circuit B	A	-	-	-	-	-	-	234	257	257	328
Option 81	A	-	-	-	-	-	-	468	514	585	656
Max. current drawn (Un -10%)^⑨											
Circuit A	A	190	255	280	357	387	404	255	280	357	357
Circuit B	A	-	-	-	-	-	-	255	280	280	357
Option 81	A	-	-	-	-	-	-	510	560	637	714

- ① Instantaneous start-up current (maximum operating current of the smallest compressor(s) + locked rotor current or reduced start-up current of the largest compressor). Values obtained at standard Eurovent conditions: evaporator entering/leaving water temp. = 12°C/7°C, condenser entering/leaving water temp. = 30°C/35°C.
- ② Instantaneous start-up current (maximum operating current of the smallest compressor(s) + locked rotor current or reduced start-up current of the largest compressor). Values obtained at operation with maximum unit power input.
- ③ Values obtained at standard Eurovent conditions: evaporator entering/leaving water temp. = 12°C/7°C, condenser entering/leaving water temp. = 30°C/35°C.
- ④ Values obtained at operation with maximum unit power input.
- ⑤ Values obtained at operation with maximum unit power input. Values given on the unit nameplate.

Dimensions/clearances

30XW-PZE/30XWHPZE 301-651

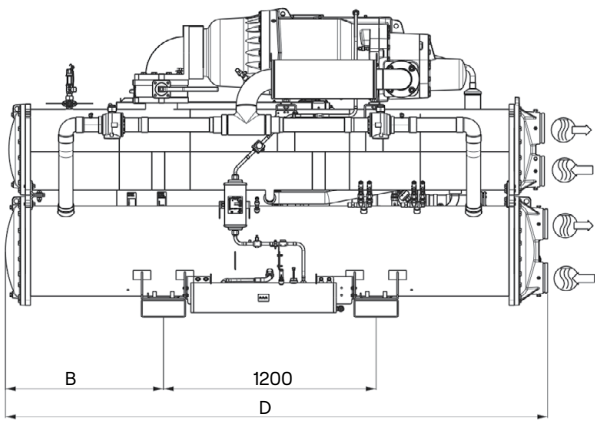
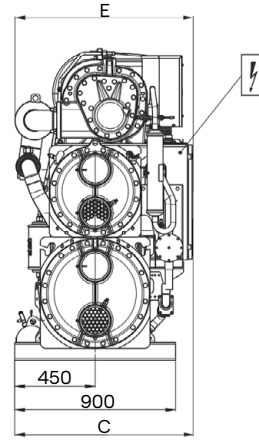
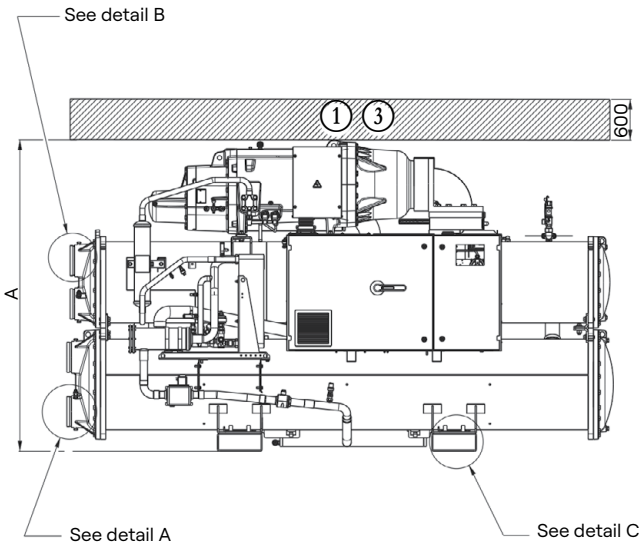

Dimensions in mm

	A	B	C	D	E	F	G	H
--	---	---	---	---	---	---	---	---

30XW-PZE / 30XWHPZE

301	1612	800	982	2724	983	141,3	141,3	2600
401	1743	968	980	3059	982	168,3	168,3	2800
451	1743	968	980	3059	982	168,3	168,3	2800
551	1950	1083	1080	3290	1180	219,1	219,1	3100
601	1950	1083	1080	3290	1180	219,1	219,1	3100
651	1950	1083	1080	3290	1180	219,1	219,1	3100

30XW-PZE / 30XWHPZE (option 150)

301	1612	800	982	2724	983	141,3	141,3	2600
401	1743	968	980	3059	982	168,3	168,3	2800
451	1743	968	1040	3059	1042	168,3	168,3	2800
551	1968	1083	1080	3290	1180	219,1	219,1	3100
601	1968	1083	1080	3290	1180	219,1	219,1	3100
651	1968	1083	1080	3290	1180	219,1	219,1	3100

Inlet air connection (except opt 330)

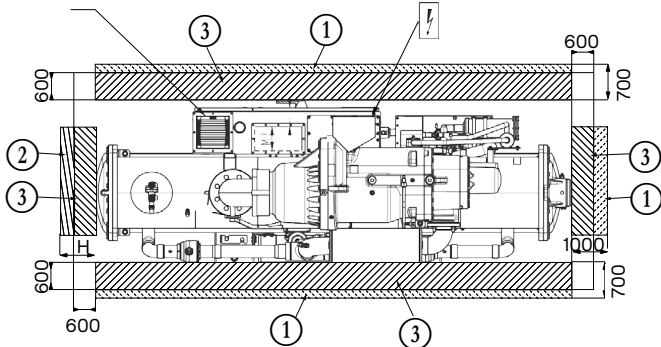

Legend

All dimensions are given in mm.

- ① Services clearances required
- ② Space required to remove cooler tubes
- ③ Zone ATEX
- Inlet water
- Outlet water
- Electrical supply entry

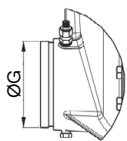

Detail A

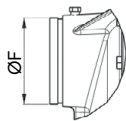

Detail B

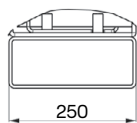

Detail C

NOTES:

- Drawings are not contractually binding. Before designing an installation, consult the certified dimensional drawings supplied with the unit or available on request.
- For the positioning of the fixing points, weight distribution and centre of gravity coordinates please refer to the dimensional drawings.

Dimensions/clearances

30XW-PZE/30XWHPZE 801-1101

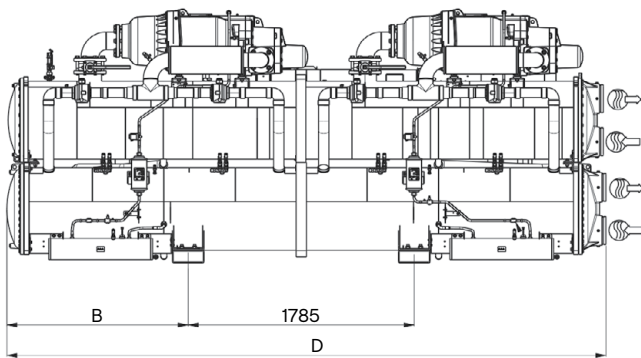
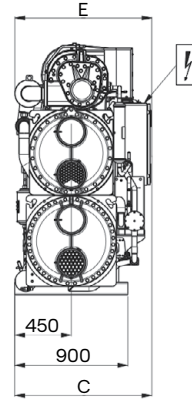
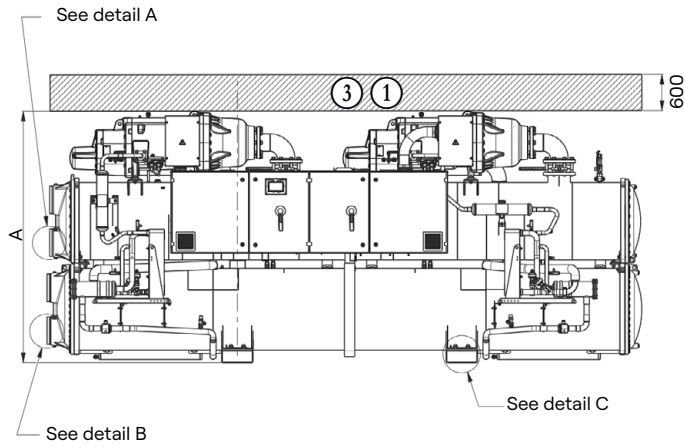

Inlet air connection
160 × 160 (except opt 330)

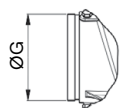
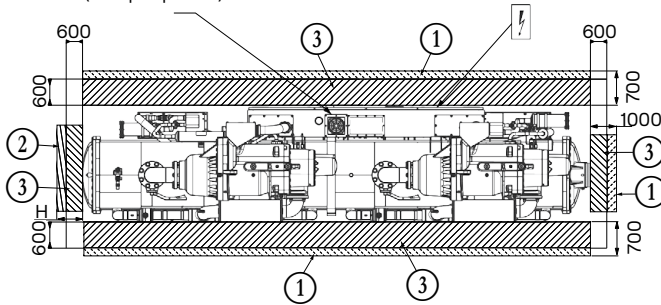

Detail A

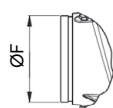

Detail B

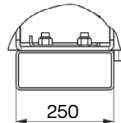

Detail C

	Dimensions in mm							
	A	B	C	D	E	F	G	H

30XW-PZE / 30XWHPZE

801	1998	1512	1121	4730	1124	219,1	219,1	4500
901	1998	1512	1125	4730	1124	219,1	219,1	4500
1001	2051	1512	1238	4730	1238	219,1	219,1	4500
1101	2051	1512	1238	4730	1238	219,1	219,1	4500

30XW-PZE / 30XWHPZE (option 150)

801	1998	1512	1121	4730	1124	219,1	219,1	4500
901	1998	1512	1125	4730	1124	219,1	219,1	4500
1001	2070	1512	1238	4730	1238	219,1	219,1	4500
1101	2051	1512	1238	4730	1238	219,1	219,1	4500

Legend

All dimensions are given in mm.

- ① Services clearances required
- ② Space required to remove cooler tubes
- ③ Zone ATEX
- Inlet water
- Outlet water
- Electrical supply entry

NOTES:

- Drawings are not contractually binding. Before designing an installation, consult the certified dimensional drawings supplied with the unit or available on request.
- For the positioning of the fixing points, weight distribution and centre of gravity coordinates please refer to the dimensional drawings.