

**AQUASNAP®**  
**AQUASNAP®**  
Heating



## 61WG/ 30WG-A

Water-Cooled  
Liquid Chillers and Water-  
Sourced Heat Pumps

30WG optimized for cooling  
61WG optimized for heating  
Compact design  
Plug and play approach  
High efficiency

Nominal cooling capacity  
25-190 kW

Nominal heating capacity  
29-230 kW



CARRIER participates in the ECP programme for LCP-HP  
Check ongoing validity of certificate:  
[www.eurovent-certification.com](http://www.eurovent-certification.com)



The 30WG and 61WG units are new Carrier chillers and heat pumps designed for commercial (offices, small hotels, leisure facilities), residential and industrial applications. All units offer a unique combination of high performance and functionality in an exceptionally compact chassis.

61WG units are designed for high-temperature heating applications with hot water production possible up to 65 °C. The 30WG, is designed for air-conditioning applications with a high SEER value. As they can produce chilled water down to -12 °C they are also suitable for process applications.

A large number of options is available for the whole range:

- Hydraulic modules with or without variable water flow rate.
- Reinforced sound insulation.
- Stacking and connection of two units.
- Low-temperature applications down to -12 °C (30WG only).



## Customer benefits

### Features

- Reduced footprint.
- Scroll compressors and R-410A refrigerant.
- Variable-flow pump.
- Low-noise option (-3 dB(A)).
- Stacking of two units for increased capacity (up to size 090).
- Several communication protocols available: JBus, BacNet, MS/TP, LON.
- Water connection at the top or rear (30WG/61WG only).

### Available versions

#### 61WG - optimised for heating

- High temperature up to +65 °C.
- Evaporator temperature down to -5 °C.
- Control of the three-way diverter valve for domestic hot water and space heating requirements.
- System approach - the Heating System Manager maximises the global efficiency of complex systems where the 61WG units are combined with an auxiliary heating source to serve multi-zone space heating and domestic hot water production.

#### 30WG - optimised for air conditioning and process Heating & Cooling

- Evaporator temperature down to -12 °C.
- Condenser temperature up to +60 °C.
- Condensing pressure control devices available.

#### The right unit for any application

- The high temperature of the 61WG units makes them compatible with most heating systems, both in new and refurbished buildings and permits domestic hot water production (with a dedicated temperature setpoint).
- Option 153 "Built-in DHW and space heating control" allows control of both domestic hot water and space heating requirements:
  - Domestic hot water production: a built-in three-way valve is directed to divert the heat flow from the space heating loop to the domestic hot water loop and vice versa.
  - Space heating control: the setpoint is adjustable, based on the daily schedule or the outside air temperature (weather compensation function).
  - Control of auxiliary systems: if an alarm is detected at the 61WG/30WG or if there is insufficient heating capacity, a digital signal starts an auxiliary electric heater (1 to 4 stages) or boiler.
  - Pump control: allows control of the built-in pump as well as the pump in the secondary loop (to terminals).

- In 30WG units the pressure control signal ensures safe unit operation and maximised performance at low source-side water temperatures.
- In 61WG/30WG units the Heating System Manager (HSM) accessory allows control of systems with several heat sources and different additional systems: electric heat, boiler or for the most complex systems district heating (see pages 9 to 11).

#### Adaptability and simple installation

- The 30WG and 61WG units can be provided with several hydraulic module options, both on the evaporator and/or condenser side, with different levels of available pressure and variable or fixed-speed pumps (see page 7).
- If option 153 is selected domestic hot water production is controlled via a built-in three-way diverter valve (not supplied).
- 61WG and 30WG units offer water-side cooling/heating reversibility.

#### Water connections at the rear of the unit



#### Internal view of 61WG unit with hydraulic module

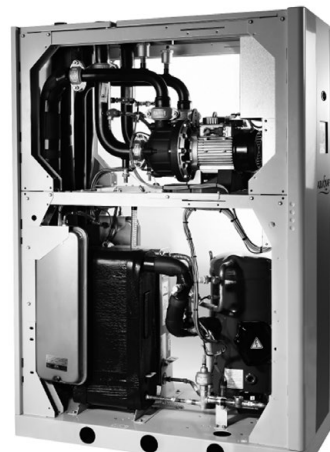

## Customer benefits

**Internal view of 30WG 170**



**Component accessibility**

See photos below.

**Access to scroll compressors**

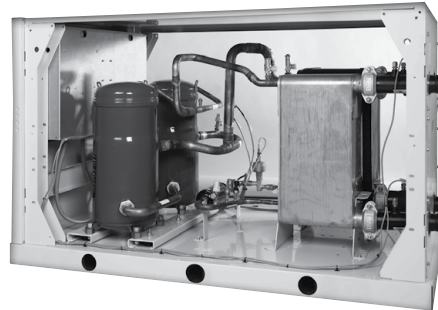

**Water connections at the top of the unit**



**Access to control panel**

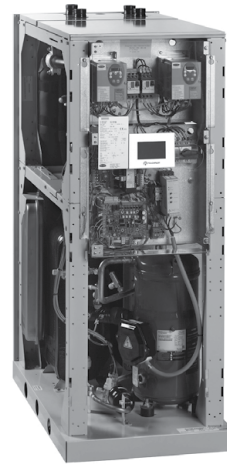

### A compact high-performance product range

- Small footprint, ideal for refurbished buildings, allows access in very tight plant rooms.
- 61WG: High SCOP satisfies even the most stringent standards, with a leaving water temperature of up to 65 °C without supplementary system.
- 30WG: High SEER and SEPR.
- Units optimized for process and comfort applications.
- Variable-flow pumps reduce system energy consumption.
- The entire range offers low sound levels, allowing installation in any building type. The low-noise option ensures enhanced acoustic comfort (-3 dB(A)).
- 61WG/30WG units are equipped with the latest generation R-410A scroll compressor, optimised for typical operating conditions for water-sourced units.

**Two-unit stacking option for reduced footprint size  
020-090**

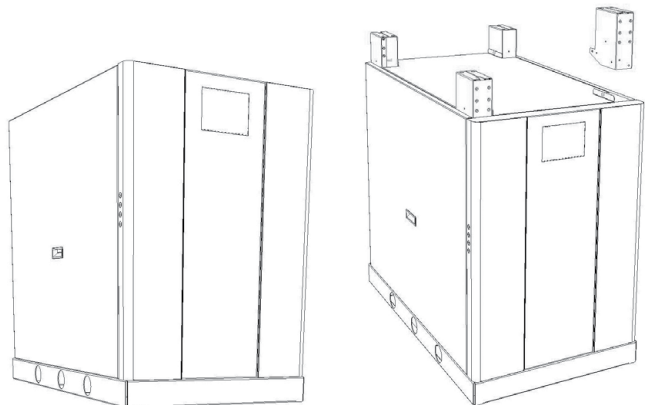

## Customer benefits

### SmartVu™ control

The SmartVu™ control combines intelligence with operating simplicity. The control constantly monitors all machine parameters and precisely manages the operation of compressors, expansion devices, fans and the evaporator water pump for optimum energy efficiency.

The SmartVu™ control features advanced communication technology over Ethernet (IP) and a user-friendly and intuitive user interface with 4.3-inch colour touch screen.

- Energy management configuration:
  - Internal timer: controls chiller on/off times and operation at a second setpoint.
  - Setpoint offset based on the outdoor air temperature.
  - Lead/lag control of two chillers operating in parallel with runtime balancing and automatic changeover in case of a unit fault.
  - Innovative smart energy monitoring, providing users with smart data such as real-time electrical energy consumption and cooling capacity, and instantaneous and average energy efficiency values.
  - For further energy savings, the AquaSnap® can be monitored remotely by Carrier experts for energy consumption diagnosis and optimisation.
- Integrated features:
  - Night mode: Capacity and fan speed limitation for reduced noise level.
  - With hydraulic module: Water pressure display and water flow rate calculation.
- Advanced communication features:
  - Easy and high-speed communication technology over Ethernet (IP) to a centralised building management system.
  - Access to multiple unit parameters.
- Maintenance functions:
  - F-Gas regulation leak check reminder alert.
  - Maintenance alert can be configured to days, months or hours of operation.
  - Display of trend curves for the main values.
  - Management of a fault memory allowing a log of the last 50 incidents to be accessed, with operating readings taken when the fault occurs.
  - Blackbox memory.

- 4"3 SmartVu™ user interface:

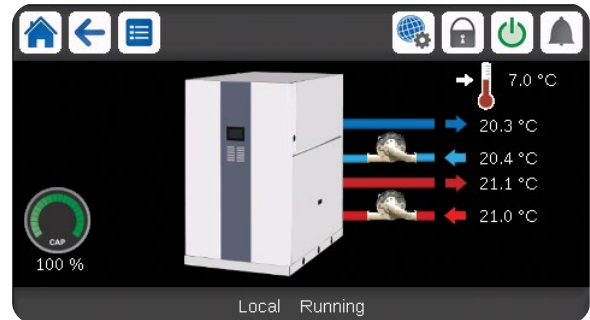

- Intuitive and user-friendly 4"3 inch touch screen interface.
- Concise and clear information is available in local languages.
- Complete menu, customised for different users (end user, service personnel or Carrier engineers).

### Remote management (standard)

Units with SmartVu™ control can be easily accessed from the internet, using a PC with an Ethernet connection. This makes remote control quick and easy and offers significant advantages for service operations.

The AquaSnap® is equipped with an RS485 serial port that offers multiple remote control, monitoring and diagnostic possibilities. Carrier offers a vast choice of control products, specially designed to control, manage and supervise the operation of an air conditioning system. Please consult your Carrier representative for more information.

The AquaSnap® also communicates with other centralised building management systems via optional communication gateways.

A connection terminal allows the AquaSnap® unit to be remotely controlled by wire:

- Start/stop: Opening of this contact will shut down the unit.
- Dual setpoint: closing of this contact activates a second setpoint (e.g.: unoccupied mode).
- Demand limit: Closing of this contact limits the maximum chiller capacity to a predefined value.
- Operation indication: This volt-free contact indicates that the chiller is operating (cooling load).
- Alarm indication: this volt-free contact indicates the presence of a major fault that has led to the shut-down of one or several refrigerant circuits.

## Customer benefits

### 30WG units compatible the Carrier 09 series dry coolers/remote condensers

The Carrier 09 series dry coolers are compatible with the 30WG.

The chiller 30WG can control the fans of the dry cooler / remote condenser via digital or analogue outputs (according to AC or EC motors) with following options :

- For chiller 30WG : option 154.
- For dry cooler / remote condenser : dedicated control cabinet with an auxiliary board.

A simple communication bus is required between the chiller and the dry cooler/ remote condenser.

As all control components are installed and tested in the factory, installation and start-up of the unit and its associated dry cooler/remote condenser are simplified.

Control board algorithms optimise energy consumption based on:

- The outside temperature and chilled-water temperature read for dry coolers.
- The outside temperature and saturated refrigerant discharge temperature read for remote condensers.

A simple communication bus is required downstream to connect the control board to the unit control.

### 30WG system concept

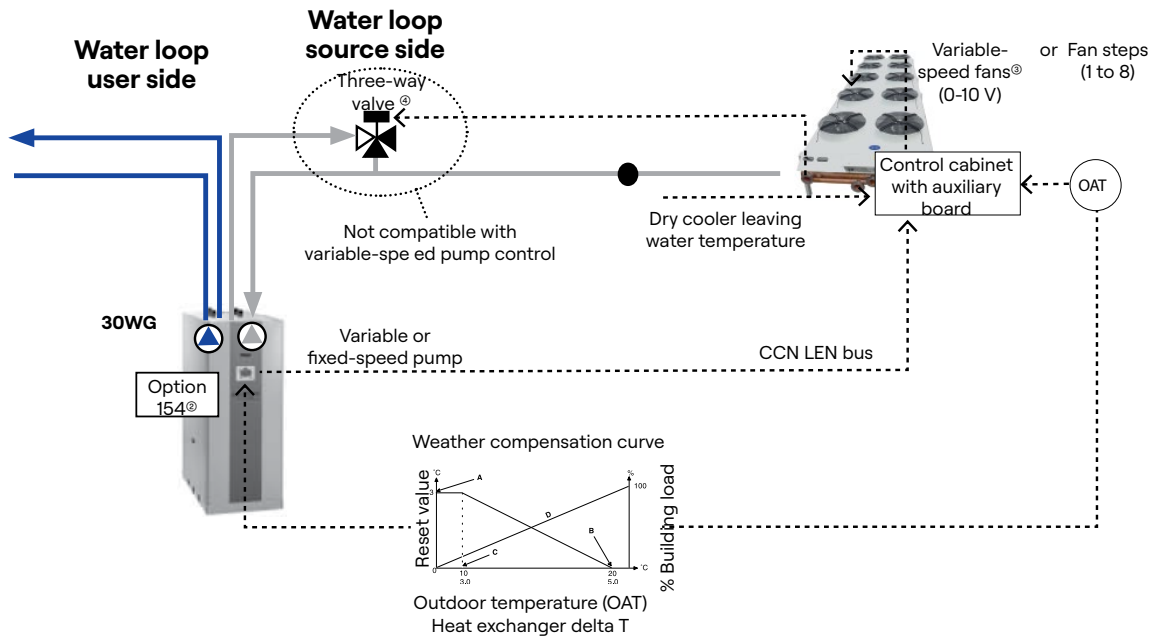

#### Legend

- CCN Carrier Comfort Network.
- LEN Local equipment network.
- OAT Outside air temperature.
- ① Control board option on 09PE dedicated to 30WG.
- ② Option 154 for connection and communication with 09PE dry cooler.
- ③ For correct operation of the unit below 0 °C variable speed fans are required.
- ④ Three-Way valve or two two-way valves optional on 09PE.

## Options

Options	No.	Description	Advantages	Use
Low-temperature brine solution	6B	Low temperature glycol solution production down to -12 °C with ethylene glycol	Covers specific applications such as ice storage and industrial processes	30WG 020-190
Soft Starter	25	Electronic starter on each compressor	Reduced start-up current	30WG 020-190 61WG 020-190
Lead/lag operation	58	Unit equipped with supplementary water outlet temperature sensor kit to be field-installed allowing lead/lag operation of two units connected in parallel	Optimised operation of two units connected in parrallele operation with operating time equalisation	30WG 020-190 61WG 020-190
External disconnect handle	70F	The handle of the electrical disconnect switch is on the outside of the unit	Quick access to the unit disconnect switch	30WG 020-190 61WG 020-190
Evap. single pump power/control circuit	84	Unit equipped with an electrical power and control circuit for one pump evaporator side	Quick and easy installation: the control of fixed speed pumps is embedded in the unit control	30WG 110-190 61WG 110-190
Cond. single pump power/control circuit	84R	Unit equipped with an electrical power and control circuit for one pump condenser side	Quick and easy installation: the control of fixed speed pumps is embedded in the unit control	30WG 110-190 61WG 110-190
Condenser insulation	86	Thermal condenser insulation	Minimizes thermal dispersions condenser side (key option for heat pump or heat recovery applications) and allows compliancy with special installation criteria (hot parts insulated)	30WG 020-190 61WG 020-190
HP single-pump hydraulic module	116R	Single high-pressure water pump, water filter, electronic water flow control, pressure transducers. For more details, refer to the dedicated chapter (expansion tank not included.Option with built-in safety hydraulic components available.)	Easy and fast installation (plug & play)	30WG 110-190 61WG 110-190
LP evap. single-pump	116T	Evaporator hydraulic module equipped with low pressure fixed-speed pump, drain valve, air vent and pressure sensors. For more details, refer to the dedicated chapter (expansion tank not included. Option with built-in safety hydraulic components available.)	Easy and fast installation (plug & play)	30WG 020-190 61WG 020-190
HP evap. variable-speed single-pump	116V	Evaporator hydraulic module equipped with high-pressure variable-speed pump, drain valve, air vent and pressure sensors. For more details, refer to the dedicated chapter (expansion tank not included. Option with built-in safety hydraulic components available.)	Easy and fast installation (plug & play), significant pumping energy cost savings (more than two-thirds), tighter water flow control, improved sytem reliability	30WG 020-190 61WG 020-190
HP VSD dual-pump hydraulic mod.	116W	Dual high-pressure water pump with variable speed drive (VSD), pressure transducers. Multiple possibilities of water flow control. For more details, refer to the dedicated chapter (expansion tank not included Option with built-in safety hydraulic components available)	Easy and fast installation (plug & play), significant pumping energy cost savings (more than two-thirds), tighter water flow control, improved sytem reliability	30WG 110-190 61WG 110-190
LP VSD single-pump	116Y	Evaporator hydraulic module equipped with low -pressure variable-speed pump, drain valve, air vent and pressure sensors. For more details, refer to the dedicated chapter (expansion tank not included. Option with built-in safety hydraulic components available.)	Easy and fast installation (plug & play), significant pumping energy cost savings (more than two-thirds), tighter water flow control, improved sytem reliability	30WG 110-190 61WG 110-190

## Options

Options	No.	Description	Advantages	Use
Lon gateway	148D	Two-directional communication board complying with Lon Talk protocol	Connects the unit by communication bus to a building management system	30WG 020-190 61WG 020-190
Bacnet over IP	149	Two-directional high-speed communication using BACnet protocol over Ethernet network (IP)	Easy and high-speed connection by ethernet line to a building management system. Allows access to multiple unit parameters	30WG 20-190 61WG 020-190
Modbus over IP and RS485	149B	Bi-directional high-speed communication using Modbus protocol over Ethernet network (IP)	Easy and high-speed connection by ethernet line to a building management system. Allows access to multiple unit parameters	30WG 020-190 61WG 020-190
Built-in DHW & space heating control	153	Control board factory-installed on the unit, control using weather compensation, control of supplementary electric heater (4 stages) or boiler, needle valve for domestic hot-water production with programmable time schedule.	Permits easy control of a basic heating system	30WG 020-190 61WG 020-090
Specific dry cooler control	154	Dedicated connection and software for 09PE dry cooler management. For 09PE dry cooler need to select the option control cabinet manage by the chiller	Permits the use of an energy-efficient plug-and-play system	30WG 020-190
Compliance with Russian regulations	199	EAC certification	Conformance with Russian regulations	30WG 020-190 61WG 020-190
Insulation of the evap. in/out ref.lines	256	Thermal insulation of the evaporator entering/leaving refrigerant lines with flexible, anti-UV insulant	Prevents condensation on the evaporator entering/leaving refrigerant lines	30WG 020-190 61WG 020-190
Low noise level	257	Compressor sound enclosure	Reduced sound emissions	30WG 020-190 61WG 020-190
Very low sound level	258	Enhanced sound insulation of main noise sources (Material classified CDOS2 fire class according to Euroclass 13-501).	6 dB(A) quieter than standard . Refer to the physical data table for detailed values	30WG 020-090 61WG 020-090
Evaporator screw connection sleeves kit	264	Evaporator inlet/outlet screw connection sleeves	Allows unit connection to a screw connector	30WG 020-140 61WG 020-140
Condenser screw connection sleeves kit	265	Condenser inlet/outlet screw connection sleeves	Allows unit connection to a screw connector	30WG 020-140 61WG 020-140
Welded evaporator connection kit	266	Victaulic piping connections with welded joints	Easy installation	30WG 020-190 61WG 020-190
Welded condenser water connection kit	267	Victaulic piping connections with welded joints	Easy installation	30WG 020-190 61WG 020-190
HP single-pump, cond. side	270R	Condenser hydraulic module equipped with high pressure fixed-speed pump, drain valve, air vent and pressure sensors. Built-in safety hydraulic components available in option.	Easy and fast installation (plug & play)	30WG 110-190 61WG 110-190
LP single-pump, cond. side	270T	Condenser hydraulic module equipped with low pressure fixed-speed pump, drain valve, air vent and pressure sensors. Built-in safety hydraulic components available in option.	Easy and fast installation (plug & play)	30WG 020-190 61WG 020-190
HP cond. variable-speed single-pump	270V	Condenser hydraulic module equipped with high-pressure variable-speed pump, drain valve, air vent and pressure sensors. (expansion tank not included) Built-in safety hydraulic components available in option.	Easy and fast installation (plug & play), reduced power consumption of the water circulation pump	30WG 020-190 61WG 020-190

## Options

Options	No.	Description	Advantages	Use
HP cond. variable-speed dual-pump	270W	Condenser hydraulic module equipped with dual high-pressure variable-speed pump, drain valve, air vent and pressure sensors. (expansion tank not included) Built-in safety hydraulic components available in option.	Easy and fast installation (plug & play), reduced power consumption of the water circulation pump	30WG 110-190 61WG 110-190
LP cond. variable-speed single-pump	270Y	Condenser hydraulic module equipped with low-pressure variable-speed pump, drain valve, air vent and pressure sensors. (expansion tank not included) Built-in safety hydraulic components available in option.	Easy and fast installation (plug & play), reduced power consumption of the water circulation pump	30WG 110-190 61WG 110-190
High-temp. water prod. with glycol solution on the evap.	272	Condenser side water production up to 65 °C, with glycol solution on the evaporator side to -5 °C	Geothermal application and domestic hot-water production	61WG 020-190
Unit stackable for operation	273	Unit stackable for operation	Reduced footprint size	30WG 020-090 61WG 020-090
Water connection at the top	274	Customer water connection at the top of the unit	Reduced footprint size	30WG 020-190 61WG 020-190
Safety hydraulic components, evap. side	293	Screen filter, expansion tank and relief valve integrated in the evaporator hydraulic module	Easy and fast installation (plug & play), operating safety	30WG 020-190 61WG 020-190
Safety hydraulic components, cond. side	293A	Screen filter, expansion tank and relief valve integrated in the condenser hydraulic module	Easy and fast installation (plug & play), operating safety	30WG 020-190 61WG 020-190
Set point adjustment by 4-20mA signal	311	Connections to allow a 4-20mA signal input	Easy energy management, allow to adjust set point by a 4-20mA external signal	30WG 020-190 61WG 020-190
External temperature sensor	312	External temperature sensor control for using weather compensation	Allow to adjust set point using weather compensation and define autorisation operation mode to external temperature	30WG 020-190 61WG 020-190
Free Cooling dry cooler management	313	Control & connections to a Free Cooling dry cooler 09PE or 09VE fitted with option FC control box	Easy system management, Extended control capabilities to a dry cooler used in Free Cooling mode	30WG 020-190

## Physical data, 61WG units

61WG			020	025	030	035	040	045	050	060	070	080	090		
<b>Heating</b>															
<b>Standard unit</b> Full load performances*	HW1	Nominal capacity	kW	29	34	38	44	50	57	69	78	88	100	117	
		COP	kW/kW	5,42	5,29	5,21	5,29	5,34	5,32	5,49	5,36	5,46	5,28	5,33	
	HW2	Nominal capacity	kW	28	33	37	43	49	55	66	76	84	95	109	
		COP	kW/kW	4,35	4,34	4,20	4,27	4,32	4,36	4,51	4,32	4,35	4,27	4,31	
	HW3	Nominal capacity	kW	27	32	35	41	47	52	64	74	80	90	103	
		COP	kW/kW	3,65	3,68	3,52	3,59	3,56	3,66	3,75	3,64	3,63	3,56	3,60	
	HW4	Nominal capacity	kW	26	31	34	40	43	49	61	71	76	85	97	
		COP	kW/kW	2,96	2,96	2,86	2,93	2,88	2,96	2,98	3,04	2,99	2,94	2,97	
	HB1	Nominal capacity	kW	22	26	29	34	38	42	50	57	67	75	87	
		COP	kW/kW	4,24	4,26	4,29	4,27	4,27	4,25	4,25	4,27	4,26	4,28	4,29	
	<b>Standard unit</b> Seasonal energy efficiency**	HW1	SCOP <sub>30/35°C</sub>	kW/kW	5,36	5,20	5,11	5,19	5,23	5,19	5,84	5,93	5,93	5,83	5,82
			$\eta_s$ heat <sub>30/35°C</sub>	%	206	200	197	200	201	200	226	229	229	225	225
HW3		<b>SCOP<sub>47/55°C</sub></b>	<b>kW/kW</b>	<b>4,37</b>	<b>4,32</b>	<b>4,20</b>	<b>4,28</b>	<b>4,32</b>	<b>4,35</b>	<b>4,86</b>	<b>4,88</b>	<b>4,80</b>	<b>4,89</b>	<b>4,80</b>	
		<b><math>\eta_s</math> heat<sub>47/55°C</sub></b>	<b>%</b>	<b>167</b>	<b>165</b>	<b>160</b>	<b>163</b>	<b>165</b>	<b>166</b>	<b>186</b>	<b>187</b>	<b>184</b>	<b>188</b>	<b>184</b>	
		P <sub>rated</sub>	kW	32	38	42	49	56	63	76	88	97	109	124	
		Energy labelling		A++	A++	A++	A++	A++	A++	-	-	-	-	-	
<b>Operating weight<sup>①</sup></b>		kg	191	200	200	207	212	220	386	392	403	413	441		
<b>Operating weight with option 258<sup>②</sup></b>		kg	198	207	207	214	219	227	399	405	416	426	454		
<b>Sound levels<sup>③</sup></b>															
Sound power level, standard unit		dB(A)	67	68	69	69	70	70	72	72	72	73	73		
Sound power level, option 257		dB(A)	65	66	66	67	68	68	68	69	69	69	70		
Sound power level, option 258		dB(A)	61	62	63	63	64	64	66	66	66	67	67		
Sound power level, option 257+258		dB(A)	60	62	62	62	64	63	65	65	65	66	66		
<b>Dimensions, standard unit<sup>③</sup></b>															
Width		mm	600	600	600	600	600	600	880	880	880	880	880		
Length		mm	1044	1044	1044	1044	1044	1044	1474	1474	1474	1474	1474		
Height		mm	901	901	901	901	901	901	901	901	901	901	901		
<b>Compressors</b>		Hermetic scroll 48,3 r/s													
Quantity			1	1	1	1	1	1	2	2	2	2	2		
Number of capacity stages			1	1	1	1	1	1	2	2	2	2	2		
Minimum capacity		%	100	100	100	100	100	100	50	50	50	50	50		

\* In accordance with standard EN14511-3:2022.

\*\* In accordance with standard EN14825:2022, average climate.

HW1 Heating mode conditions: Evaporator entering/leaving water temperature 10°C/7°C, condenser entering/leaving water temperature 30°C/35°C, evaporator and condenser fouling factor 0 m<sup>2</sup>. k/W.

HW2 Heating mode conditions: Evaporator entering/leaving water temperature 10°C/7°C, condenser entering/leaving water temperature 40°C/45°C, evaporator and condenser fouling factor 0 m<sup>2</sup>. k/W.

HW3 Heating mode conditions: Evaporator entering/leaving water temperature 10°C/7°C, condenser entering/leaving water temperature 47°C/55°C, evaporator and condenser fouling factor 0 m<sup>2</sup>. k/W.

HW4 Heating mode conditions: Evaporator entering/leaving water temperature 10°C/7°C, condenser entering/leaving water temperature 55°C/65°C, evaporator and condenser fouling factor 0 m<sup>2</sup>. k/W.

HB1 Heating mode conditions: Evaporator entering/leaving water temperature 0°C/-3°C, condenser entering/leaving water temperature 30°C/35°C, evaporator and condenser fouling factor 0 m<sup>2</sup>.K/W, evaporator fluid: 30% ethylene glycol.

$\eta_s$  heat<sub>30/35°C</sub> & SCOP<sub>30/35°C</sub> Values calculated in accordance with EN14825:2022.

$\eta_s$  heat<sub>47/55°C</sub> & SCOP<sub>47/55°C</sub> **Bold values compliant to Ecodesign regulation: (EU) No 813/2013 for Heat Pump application.**

- Not applicable.

① Weight shown is a guideline only. Please refer to the unit nameplate.

② In dB ref=10<sup>12</sup> W, (A) weighting. Declared dual number noise emission values in accordance with ISO 4871 (with an associated uncertainty of +/-3dB(A)). Measured in accordance with ISO 9614-1.

③ The dimensions shown are for the standard unit. For other unit types please refer to the dimensional drawings.



Eurovent certified values

CARRIER participates in the ECP programme for LCP-HP Check ongoing validity of certificate:  
www.eurovent-certification.com

## Physical data, 61WG units

61WG		020	025	030	035	040	045	050	060	070	080	090
<b>Refrigerant<sup>Ⓞ</sup></b>		R-410A (GWP=2088 Following AR4)										
Charge, standard unit	kg	3,5	3,5	3,6	3,7	4,0	4,6	7,6	7,8	7,9	8,7	11,5
	teqCO <sub>2</sub>	7,2	7,3	7,4	7,6	8,2	9,5	15,9	16,3	16,5	18,2	24
Charge, unit with option 272	kg	2,7	2,9	2,9	3,0	3,2	3,9	7,2	7,3	7,4	7,6	10,5
	teqCO <sub>2</sub>	5,6	6,0	6,1	6,3	6,7	8,1	14,9	15,2	15,5	15,9	21,9
<b>Capacity control</b>		SmartVu™										
<b>Evaporator</b>		Direct-expansion plate heat exchanger										
Water volume	l	3,3	3,6	3,6	4,2	4,6	5,0	8,4	9,2	9,6	10,4	12,5
Water connections		Raccordements Victaulic										
Inlet/outlet	in	1,5	1,5	1,5	1,5	1,5	1,5	2	2	2	2	2
Max. water-side operating pressure without hydraulic module	kPa	1000	1000	1000	1000	1000	1000	1000	1000	1000	1000	1000
<b>Condenser</b>		Plate heat exchanger										
Net water volume	l	3,3	3,6	3,6	4,2	4,6	5,0	8,4	9,2	9,6	10,4	12,5
Water connections		Victaulic										
Inlet/outlet	in	1,5	1,5	1,5	1,5	1,5	1,5	2	2	2	2	2
Max. water-side operating pressure without hydraulic module	kPa	1000	1000	1000	1000	1000	1000	1000	1000	1000	1000	1000
<b>Chassis paint color</b>		Color code: RAL7035										

Ⓞ Weight shown is a guideline only. Please refer to the unit nameplate.

## Physical data, 61WG units

61WG			110	120	140	150	170	190	
<b>Heating</b>									
<b>Standard unit</b> Full load performances*	HW1	Nominal capacity	kW	135	151	175	183	204	235
		COP	kW/kW	5,48	5,44	5,44	5,62	5,49	5,48
	HW2	Nominal capacity	kW	131	147	168	176	197	226
		COP	kW/kW	4,56	4,53	4,55	4,63	4,52	4,53
	HW3	Nominal capacity	kW	124,4	140,7	161,3	166,0	186,2	212,5
		COP	kW/kW	3,58	3,48	3,56	3,53	3,42	3,49
	HW4	Nominal capacity	kW	118	131	150	157	174	200
		COP	kW/kW	2,83	2,74	2,85	2,86	2,70	2,85
	HB1	Nominal capacity	kW	102	114	133	135	153	177
		COP	kW/kW	4,42	4,39	4,42	4,40	4,39	4,38
<b>Standard unit</b> Seasonal energy efficiency**	HW1	SCOP <sub>30/35°C</sub>	kW/kW	6,20	6,32	6,24	6,18	6,19	6,03
		η <sub>s heat</sub> <sub>30/35°C</sub>	%	241	245	242	240	240	234
	HW3	SCOP <sub>47/55°C</sub>	kW/kW	<b>5,03</b>	<b>5,03</b>	<b>5,03</b>	<b>5,02</b>	<b>5,05</b>	<b>4,93</b>
		η <sub>s heat</sub> <sub>47/55°C</sub>	%	<b>194</b>	<b>193</b>	<b>193</b>	<b>194</b>	<b>194</b>	<b>190</b>
		P <sub>rated</sub>	kW	144	162	185	193	215	247
			kg	707	733	758	841	877	908
<b>Operating weight</b> ①									
<b>Sound levels</b> ②									
Sound power level, standard unit			dB(A)	76	77	78	76	77	78
Sound power level, option 257			dB(A)	73	74	75	73	74	75
<b>Dimensions, standard unit</b> ③									
Width			mm	880	880	880	880	880	880
Length			mm	1583	1583	1583	1583	1583	1583
Height			mm	1574	1574	1574	1574	1574	1574
<b>Compressors</b>									
Hermetic scroll 48,3 r/s									
Quantity				3	3	3	4	4	4
Number of capacity stages				3	3	3	4	4	4
Minimum capacity			%	33	33	33	25	25	25
<b>Refrigerant</b> ③									
R-410A (GWP=2088 Following AR4)									
Charge, standard unit			kg	13,3	14,5	15,6	21,0	23,0	24,2
			teqCO <sub>2</sub>	27,8	30,3	32,6	43,8	48,0	50,5
<b>Capacity control</b>									
SmartVu™									

\* In accordance with standard EN14511-3:2022.

\*\* In accordance with standard EN14825:2022, average climate.

HW1 Heating mode conditions: Evaporator entering/leaving water temperature 10°C/7°C, condenser entering/leaving water temperature 30°C/35°C, evaporator and condenser fouling factor 0 m<sup>2</sup>. k/W.

HW2 Heating mode conditions: Evaporator entering/leaving water temperature 10°C/7°C, condenser entering/leaving water temperature 40°C/45°C, evaporator and condenser fouling factor 0 m<sup>2</sup>. k/W.

HW3 Heating mode conditions: Evaporator entering/leaving water temperature 10°C/7°C, condenser entering/leaving water temperature 47°C/55°C, evaporator and condenser fouling factor 0 m<sup>2</sup>. k/W.

HW4 Heating mode conditions: Evaporator entering/leaving water temperature 10°C/7°C, condenser entering/leaving water temperature 55°C/65°C, evaporator and condenser fouling factor 0 m<sup>2</sup>. k/W.

HB1 Heating mode conditions: Evaporator entering/leaving water temperature 0°C/-3°C, condenser entering/leaving water temperature 30°C/35°C, evaporator and condenser fouling factor 0 m<sup>2</sup>.K/W, evaporator fluid: 30% ethylene glycol.

η<sub>s heat</sub><sub>30/35°C</sub> & SCOP<sub>30/35°C</sub> Values calculated in accordance with EN14825:2022.

η<sub>s heat</sub><sub>47/55°C</sub> & SCOP<sub>47/55°C</sub> **Bold values compliant to Ecodesign regulation: (EU) No 813/2013 for Heat Pump application.**

① Weight shown is a guideline only. Please refer to the unit nameplate.

② In dB ref=10<sup>2</sup> W, (A) weighting. Declared dual number noise emission values in accordance with ISO 4871 (with an associated uncertainty of +/-3dB(A)). Measured in accordance with ISO 9614-1.

③ The dimensions shown are for the standard unit. For other unit types please refer to the dimensional drawings.



Eurovent certified values

CARRIER participates in the ECP programme for LCP-HP Check ongoing validity of certificate:  
www.eurovent-certification.com

## Physical data, 61WG units

61WG		110	120	140	150	170	190
<b>Evaporator</b>		Direct-expansion plate heat exchanger					
Water volume	l	15,18	17,35	19,04	23,16	26,52	29,05
Water connections		Victaulic					
Inlet/outlet	in	2 1/2	2 1/2	2 1/2	3	3	3
Max. water-side operating pressure without hydraulic module	kPa	1000	1000	1000	1000	1000	1000
<b>Condenser</b>		Plate heat exchanger					
Net water volume	l	15,18	17,35	19,04	23,16	26,52	29,05
Water connections		Victaulic					
Inlet/outlet	in	2 1/2	2 1/2	2 1/2	3	3	3
Max. water-side operating pressure without hydraulic module	kPa	1000	1000	1000	1000	1000	1000
<b>Chassis paint color</b>		Color code: RAL7035					

## Physical data, 30WG units , sizes 020 to 090

30WG			020	025	030	035	040	045	050	060	070	080	090	
<b>Heating</b>														
<b>Standard unit Full load performances*</b>	HW1	Nominal capacity	kW	30	35	38	44	50	56	70	77	89	101	114
		COP	kW/kW	5,53	5,53	5,49	5,52	5,49	5,51	5,58	5,48	5,53	5,46	5,50
	HW2	Nominal capacity	kW	29	33	36	43	49	54	68	74	85	97	108
		COP	kW/kW	4,34	4,37	4,35	4,36	4,40	4,35	4,39	4,35	4,32	4,40	4,32
	HW3	Nominal capacity	kW	28	33	35	41	47	52	65	73	81	93	103
		COP	kW/kW	3,59	3,63	3,61	3,60	3,67	3,61	3,58	3,62	3,54	3,70	3,56
<b>Standard unit Seasonal energy efficiency**</b>	HW1	SCOP <sub>30/35°C</sub>	kW/kW	5,46	5,45	5,36	5,40	5,35	5,38	6,12	6,08	6,09	6,11	6,09
		η <sub>s heat</sub> <sub>30/35°C</sub>	%	211	210	206	208	206	207	237	235	235	236	235
	HW3	<b>SCOP<sub>47/55°C</sub></b>	<b>kW/kW</b>	<b>4,36</b>	<b>4,37</b>	<b>4,34</b>	<b>4,37</b>	<b>4,40</b>	<b>4,34</b>	<b>4,91</b>	<b>4,96</b>	<b>4,85</b>	<b>5,08</b>	<b>4,91</b>
		<b>η<sub>s heat</sub><sub>47/55°C</sub></b>	<b>%</b>	<b>167</b>	<b>167</b>	<b>166</b>	<b>167</b>	<b>168</b>	<b>166</b>	<b>188</b>	<b>190</b>	<b>186</b>	<b>195</b>	<b>188</b>
		P <sub>rated</sub>	kW	32	37	40	47	54	59	75	83	93	106	118
		Energy labelling		A++	A++	A++	A++	A++	A++	-	-	-	-	-
<b>Cooling</b>														
<b>Standard unit Full load performances*</b>	CW1	Nominal capacity	kW	25	29	32	37	42	47	58	63	74	84	95
		EER	kW/kW	4,72	4,72	4,69	4,73	4,69	4,72	4,72	4,65	4,69	4,65	4,68
		Eurovent class		B	B	B	B	B	B	B	B	B	B	B
	CW2	Nominal capacity	kW	34	39	43	50	57	66	79	86	102	113	129
		EER	kW/kW	6,42	6,10	6,03	6,04	5,90	6,06	6,12	5,95	6,19	5,93	6,13
		Eurovent class		A	A	A	A	A	A	A	A	A	A	A
<b>Standard unit Seasonal energy efficiency**</b>		SEER <sub>12/7°C</sub> Comfort low temp.	kW/kW	4,94	4,94	4,83	4,87	4,85	4,88	5,70	5,62	5,58	5,72	5,68
		SEPR <sub>12/7°C</sub> Process high temp.	kW/kW	6,42	6,44	6,26	6,22	6,26	6,31	6,63	6,50	6,48	6,59	6,62
<b>Unit with option 6B Seasonal energy efficiency**</b>		SEPR <sub>-2/-8°C</sub> Process medium temp.***	kWh/kWh	3,92	4,26	4,43	4,34	4,47	4,01	4,12	4,73	4,55	4,78	4,76
<b>Integrated part load value</b>		IPLV.SI	kW/kW	5,840	5,850	5,760	5,780	5,770	5,820	6,580	6,680	6,560	6,810	6,720
<b>Operating weight<sup>①</sup></b>			kg	191	200	200	207	212	220	386	392	403	413	441
<b>Operating weight with option 258<sup>①</sup></b>			kg	198	207	207	214	219	227	399	405	416	426	454

\* In accordance with standard EN14511-3:2022.

\*\* In accordance with standard EN14825:2022, average climate.

\*\*\* With EG 30%.

HW1 Heating mode conditions: Evaporator entering/leaving water temperature 10°C/7°C, condenser entering/leaving water temperature 30°C/35°C, evaporator and condenser fouling factor 0 m<sup>2</sup>. k/W.HW2 Heating mode conditions: Evaporator entering/leaving water temperature 10°C/7°C, condenser entering/leaving water temperature 40°C/45°C, evaporator and condenser fouling factor 0 m<sup>2</sup>. k/W.HW3 Heating mode conditions: Evaporator entering/leaving water temperature 10°C/7°C, condenser entering/leaving water temperature 47°C/55°C, evaporator and condenser fouling factor 0 m<sup>2</sup>. k/W.CW1 Cooling mode conditions: Evaporator water entering/leaving temperature 12°C/7°C, condenser entering/leaving water temperature 30°C/35°C, evaporator and condenser fouling factor 0 m<sup>2</sup>. K/W.CW2 Cooling mode conditions: Evaporator water entering/leaving temperature 23°C/18°C, condenser entering/leaving water temperature 30°C/35°C, evaporator and condenser fouling factor 0 m<sup>2</sup>. K/W.η<sub>s heat</sub><sub>30/35°C</sub> & SCOP<sub>30/35°C</sub> Values calculated in accordance with EN14825:2022.η<sub>s heat</sub><sub>47/55°C</sub> & SCOP<sub>47/55°C</sub> **Bold values compliant to Ecodesign regulation: (EU) No 813/2013 for Heat Pump application.**SEER<sub>12/7°C</sub> & SEPR<sub>12/7°C</sub> Values calculated in accordance with EN14825:2022.SEPR<sub>-2/-8°C</sub> Values calculated in accordance with EN14825:2022.

- Not applicable.

IPLV.SI Calculations according to standard performances AHRI 551-591 (SI).

① Weight shown is a guideline only. Please refer to the unit nameplate.



Eurovent certified values

CARRIER participates in the ECP programme for LCP-HP Check ongoing validity of certificate:  
www.eurovent-certification.com

## Physical data, 30WG units , sizes 020 to 090

30WG		020	025	030	035	040	045	050	060	070	080	090
<b>Sound levels<sup>①</sup></b>												
Sound power level, standard unit	dB(A)	67	68	69	69	70	70	72	72	72	73	73
Sound power level, option 257	dB(A)	65	66	66	67	68	68	68	69	69	69	70
Sound power level, option 258	dB(A)	61	62	63	63	64	64	66	66	66	67	67
Sound power level, option 257 + 258	dB(A)	60	62	62	62	64	63	65	65	65	66	66
<b>Dimensions, standard unit<sup>②</sup></b>												
Width	mm	600	600	600	600	600	600	880	880	880	880	880
Length	mm	1044	1044	1044	1044	1044	1044	1474	1474	1474	1474	1474
Height	mm	901	901	901	901	901	901	901	901	901	901	901
<b>Compressors</b>												
Hermetic scroll 48,3 r/s												
Quantity		1	1	1	1	1	1	2	2	2	2	2
Number of capacity stages		1	1	1	1	1	1	2	2	2	2	2
Minimum capacity	%	100	100	100	100	100	100	50	50	50	50	50
<b>Refrigerant<sup>③</sup></b>												
R-410A (GWP=2088 Following AR4)												
Charge, standard unit	kg	3,5	3,5	3,6	3,7	4,0	4,6	7,6	7,8	7,9	8,7	11,5
	teqCO <sub>2</sub>	7,2	7,3	7,4	7,6	8,2	9,5	15,9	16,3	16,5	18,2	24
<b>Capacity control</b>												
SmartVu™												
<b>Evaporator</b>												
Direct-expansion plate heat exchanger												
Water volume	l	3,3	3,6	3,6	4,2	4,6	5,0	8,4	9,2	9,6	10,4	12,5
Water connections												
Victaulic												
Inlet/outlet	in	1,5	1,5	1,5	1,5	1,5	1,5	2	2	2	2	2
Max. water-side operating pressure without hydraulic module	kPa	1000	1000	1000	1000	1000	1000	1000	1000	1000	1000	1000
<b>Condenser</b>												
Plate heat exchanger												
Net water volume	l	3,3	3,6	3,6	4,2	4,6	5,0	8,4	9,2	9,6	10,4	12,5
Water connections												
Victaulic												
Inlet/outlet	in	1,5	1,5	1,5	1,5	1,5	1,5	2	2	2	2	2
Max. water-side operating pressure without hydraulic module	kPa	1000	1000	1000	1000	1000	1000	1000	1000	1000	1000	1000
<b>Chassis paint color</b>												
Color code: RAL7035												

① Weight shown is a guideline only. Please refer to the unit nameplate.

② In dB ref=10<sup>2</sup> W, (A) weighting. Declared dualnumber noise emission values in accordance with ISO 4871 (with an associated uncertainty of +/-3dB(A)). Measured in accordance with ISO 9614-1.

③ The dimensions shown are for the standard unit. For other unit types please refer to the dimensional drawings.

# Physical data, 30WG units, sizes 110 to 190

30WG			110	120	140	150	170	190	
<b>Heating</b>									
<b>Standard unit</b> Full load performances*	HW1	Nominal capacity	kW	135	152	175	183	207	238
		COP	kW/kW	5,50	5,50	5,42	5,58	5,59	5,50
	HW2	Nominal capacity	kW	131	148	163	174	197	218
		COP	kW/kW	4,44	4,45	4,38	4,41	4,50	4,38
	HW3	Nominal capacity		125	140	160	166	187	214
		COP		3,56	3,45	3,54	3,55	3,44	3,53
<b>Standard unit</b> Seasonal energy efficiency**	HW1	SCOP <sub>30/35°C</sub>	kW/kW	6,31	6,37	6,31	6,31	6,32	6,18
		η <sub>s heat</sub> <sub>30/35°C</sub>	%	244	247	244	244	245	239
	HW3	<b>SCOP<sub>47/55°C</sub></b>	<b>kW/kW</b>	<b>5,05</b>	<b>5,09</b>	<b>5,05</b>	<b>5,02</b>	<b>5,17</b>	<b>4,96</b>
		<b>η<sub>s heat</sub><sub>47/55°C</sub></b>	<b>%</b>	<b>194</b>	<b>196</b>	<b>194</b>	<b>193</b>	<b>199</b>	<b>190</b>
		P <sub>rated</sub>	kW	143	161	178	191	216	239
<b>Cooling</b>									
<b>Standard unit</b> Full load performances*	CW1	Nominal capacity	kW	115	130	144	153	172	192
		EER	kW/kW	4,79	4,77	4,70	4,83	4,78	4,79
		Eurovent class		B	B	B	B	B	B
	CW2	Nominal capacity	kW	155	176	196	207	231	262
		EER	kW/kW	6,20	6,10	6,01	6,23	5,97	6,14
		Eurovent class		A	A	A	A	A	A
<b>Standard unit</b> Seasonal energy efficiency**		SEER <sub>12/7°C</sub> Comfort low temp.	kW/kW	6,12	6,24	6,17	5,97	6,06	5,96
		SEPR <sub>12/7°C</sub> Process high temp.	kWh/kWh	6,98	7,13	6,90	6,54	6,62	6,41
<b>Unit with option 6B</b> Seasonal energy efficiency**		SEPR <sub>2/-8°C</sub> Process medium temp.***	kWh/kWh	4,01	4,40	4,35	4,52	4,65	4,45
<b>Integrated part load value</b>		IPLV.SI	kW/kW	6,860	6,980	6,900	6,820	6,890	6,820
<b>Operating weight</b> ®			kg	707	733	758	841	877	908
<b>Sound levels</b> ®									
		Sound power level, standard unit	dB(A)	76	77	78	76	77	78
		Sound power level, option 257	dB(A)	73	74	75	73	74	75

\* In accordance with standard EN14511-3:2022.  
 \*\* In accordance with standard EN14825:2022, average climate.  
 \*\*\* With EG 30%.  
 HW1 Heating mode conditions: Evaporator entering/leaving water temperature 10°C/7°C, condenser entering/leaving water temperature 30°C/35°C, evaporator and condenser fouling factor 0 m². k/W.  
 HW2 Heating mode conditions: Evaporator entering/leaving water temperature 10°C/7°C, condenser entering/leaving water temperature 40°C/45°C, evaporator and condenser fouling factor 0 m². k/W.  
 HW3 Heating mode conditions: Evaporator entering/leaving water temperature 10°C/7°C, condenser entering/leaving water temperature 47°C/55°C, evaporator and condenser fouling factor 0 m². k/W.  
 CW1 Cooling mode conditions: Evaporator water entering/leaving temperature 12°C/7°C, condenser entering/leaving water temperature 30°C/35°C, evaporator and condenser fouling factor 0 m². K/W.  
 CW2 Cooling mode conditions: Evaporator water entering/leaving temperature 23°C/18°C, condenser entering/leaving water temperature 30°C/35°C, evaporator and condenser fouling factor 0 m². K/W.  
 η<sub>s heat</sub><sub>30/35°C</sub> & SCOP<sub>30/35°C</sub> Values calculated in accordance with EN14825:2022.  
 η<sub>s heat</sub><sub>47/55°C</sub> & SCOP<sub>47/55°C</sub> **Bold values compliant to Ecodesign regulation: (EU) No 813/2013 for Heat Pump application.**  
 SEER<sub>12/7°C</sub> & SEPR<sub>12/7°C</sub> Values calculated in accordance with EN14825:2022.  
 SEPR<sub>2/-8°C</sub> Values calculated in accordance with EN14825:2022.  
 IPLV.SI Calculations according to standard performances AHRI 551-591 (SI).  
 ① Weight shown is a guideline only. Please refer to the unit nameplate.  
 ② In dB ref=10<sup>2</sup> W, (A) weighting. Declared dual number noise emission values in accordance with ISO 4871 (with an associated uncertainty of +/-3dB(A)). Measured in accordance with ISO 9614-1.



Eurovent certified values

CARRIER participates in the ECP programme for LCP-HP Check ongoing validity of certificate: www.eurovent-certification.com

## Physical data, 30WG units, sizes 110 to 190

30WG		110	120	140	150	170	190
<b>Dimensions, standard unit</b> <sup>①</sup>							
Width	mm	880	880	880	880	880	880
Length	mm	1583	1583	1583	1583	1583	1583
Height	mm	1574	1574	1574	1574	1574	1574
<b>Compressors</b>		Hermetic scroll 48,3 r/s					
Quantity		3	3	3	4	4	4
Number of capacity stages		3	3	3	4	4	4
Minimum capacity	%	33	33	33	25	25	25
<b>Refrigerant</b> <sup>②</sup>		R-410A (GWP=2088 Following AR4)					
Charge, standard unit	kg	13,3	14,5	15,6	21,0	23,0	24,2
	teqCO <sub>2</sub>	27,8	30,3	32,6	43,8	48,0	50,5
<b>Capacity control</b>		SmartVu™					
<b>Evaporator</b>		Direct-expansion plate heat exchanger					
Water volume	l	15,18	17,35	19,04	23,16	26,52	29,05
Water connections	-	Victaulic					
Inlet/outlet	in	2 1/2	2 1/2	2 1/2	3	3	3
Max. water-side operating pressure without hydraulic module	kPa	1000	1000	1000	1000	1000	1000
<b>Condenser</b>		Plate heat exchanger					
Net water volume	l	15,18	17,35	19,04	23,16	26,52	29,05
Water connections	-	Victaulic					
Inlet/outlet	in	2 1/2	2 1/2	2 1/2	3	3	3
Max. water-side operating pressure without hydraulic module	kPa	1000	1000	1000	1000	1000	1000
<b>Chassis paint color</b>		Color code: RAL7035					

① Weight shown is a guideline only. Please refer to the unit nameplate.

② The dimensions shown are for the standard unit. For other unit types please refer to the dimensional drawings.

## Electrical data

61WG without hydraulic module		020	025	030	035	040	045	050	060	070	080	090
<b>Power circuit</b>												
Nominal voltage	V-ph-Hz	400-3-50										
Voltage range	V	360-440										
<b>Control circuit supply</b>												
24 V, via internal transformer												
<b>Maximum start-up current draw (Un)<sup>①</sup></b>												
Standard unit	A	98	142	142	147	158	197	161,6	163	171,4	184,7	227,9
Unit with electronic starter option	A	53,9	78,1	78,1	80,9	86,9	108,4	97,7	99,2	105,2	113,6	139,2
<b>Unit power factor at maximum capacity<sup>②</sup></b>												
0,9												
<b>Maximum operating power input<sup>③</sup></b>												
kW												
9,5												
<b>Nominal unit operating current draw<sup>④</sup></b>												
A												
10,6												
<b>Maximum operating current draw (Un)<sup>⑤</sup></b>												
A												
16,1												
<b>Maximum operating current draw (Un-10%)<sup>⑤</sup></b>												
A												
17,9												
<b>Customer-side unit power reserve</b>												
Customer reserve at the 24 V control power circuit												
<b>Short-circuit stability and protection</b>												
See table below "Short-circuit stability current"												

61WG without hydraulic module		110	120	140	150	170	190
<b>Power circuit</b>							
Nominal voltage	V-ph-Hz	400-3-50					
Voltage range	V	360-440					
<b>Control circuit supply</b>							
24 V, via internal transformer							
<b>Maximum start-up current draw (Un)<sup>①</sup></b>							
Standard unit	A	195,8	211,4	258,8	220,2	238,1	289,7
Unit with electronic starter option	A	129,7	140,3	170,2	154,1	167	201,1
<b>Unit power factor at maximum capacity<sup>②</sup></b>							
0,87							
<b>Maximum operating power input<sup>③</sup></b>							
kW							
44							
<b>Nominal unit operating current draw<sup>④</sup></b>							
A							
45,6							
<b>Maximum operating current draw (Un)<sup>⑤</sup></b>							
A							
73,2							
<b>Maximum operating current draw (Un-10%)<sup>⑤</sup></b>							
A							
81,3							
<b>Customer-side unit power reserve</b>							
Customer reserve at the 24 V control power circuit							
<b>Short-circuit stability and protection</b>							
See table below "Short-circuit stability current"							

- ① Maximum instantaneous start-up current at operating limit values (maximum operating current of the smallest compressor(s) + locked rotor current or limited start-up current of the largest compressor).
- ② Maximum power input at the unit operating limits.
- ③ Values obtained at standardised Eurovent conditions: evaporator entering/leaving water temperature 10 °C/7 °C, condenser entering/leaving water temperature 30 °C/35 °C.
- ④ Maximum unit operating current at maximum unit power input and 400 V.
- ⑤ Maximum unit operating current at maximum unit power input and 360 V.

## Electrical data

30WG without hydraulic module		020	025	030	035	040	045	050	060	070	080	090
<b>Power circuit</b>												
Nominal voltage	V-ph-Hz	400-3-50										
Voltage range	V	360-440										
<b>Control circuit supply</b>												
24 V, via internal transformer												
<b>Maximum start-up current draw (Un)<sup>①</sup></b>												
Standard unit	A	98	142	142	147	158	197	161	162	170	183	226
Unit with electronic starter option	A	53,9	78,1	78,1	80,9	86,9	108,4	96,8	97,9	104,1	112,3	137,4
<b>Unit power factor at maximum capacity<sup>②</sup></b>												
0,9 0,8 0,9 0,9 0,9 0,9 0,8 0,9 0,9 0,9 0,9 0,9												
<b>Maximum operating power input<sup>③</sup></b>												
kW 9,2 10,8 11,7 13,7 15,1 17,1 21,5 23,3 27,3 30,3 34,2												
<b>Nominal unit operating current draw<sup>④</sup></b>												
A 10,5 13,2 13,8 15,6 16,2 20,2 26,4 27,6 31,2 32,4 40,4												
<b>Maximum operating current draw (Un)<sup>⑤</sup></b>												
A 15,6 18,7 19,8 23,2 25,4 29 37,4 39,6 46,4 50,8 58												
<b>Maximum operating current draw (Un-10%)<sup>⑤</sup></b>												
A 17,3 20,8 22 25,8 28,2 32,2 41,6 44 51,6 56,4 64,4												
<b>Customer-side unit power reserve</b>												
Customer reserve at the 24 V control power circuit												
<b>Short-circuit stability and protection</b>												
See table below "Short-circuit stability current"												

30WG without hydraulic module		110	120	140	150	170	190
<b>Power circuit</b>							
Nominal voltage	V-ph-Hz	400-3-50					
Voltage range	V	360-440					
<b>Control circuit supply</b>							
24 V, via internal transformer							
<b>Maximum start-up current draw (Un)<sup>①</sup></b>							
Standard unit	A	193,4	208,8	255	216,6	234,2	284
Unit with electronic starter option	A	127,3	137,7	166,4	150,5	163,1	195,4
<b>Unit power factor at maximum capacity<sup>②</sup></b>							
0,87 0,85 0,85 0,87 0,85 0,85							
<b>Maximum operating power input<sup>③</sup></b>							
kW 41 45 51 55 60 68							
<b>Nominal unit operating current draw<sup>④</sup></b>							
A 46,8 48,6 60,6 62,4 64,8 80,8							
<b>Maximum operating current draw (Un)<sup>⑤</sup></b>							
A 69,6 76,2 87 92,8 101,6 116							
<b>Maximum operating current draw (Un-10%)<sup>⑤</sup></b>							
A 77,3 84,7 96,7 103,1 112,9 128,9							
<b>Customer-side unit power reserve</b>							
Customer reserve at the 24 V control power circuit							
<b>Short-circuit stability and protection</b>							
See table below "Short-circuit stability current"							

- ① Maximum instantaneous start-up current at operating limit values (maximum operating current of the smallest compressor(s) + locked rotor current or limited start-up current of the largest compressor).
- ② Maximum power input at the unit operating limits.
- ③ Values obtained at standardised Eurovent conditions: evaporator entering/leaving water temperature 12 °C/7 °C, condenser entering/leaving water temperature 30 °C/ 35 °C.
- ④ Maximum unit operating current at maximum unit power input and 400 V.
- ⑤ Maximum unit operating current at maximum unit power input and 360 V.

# Dimensions/clearances

## 61WG/30WG 020-045 - standard unit

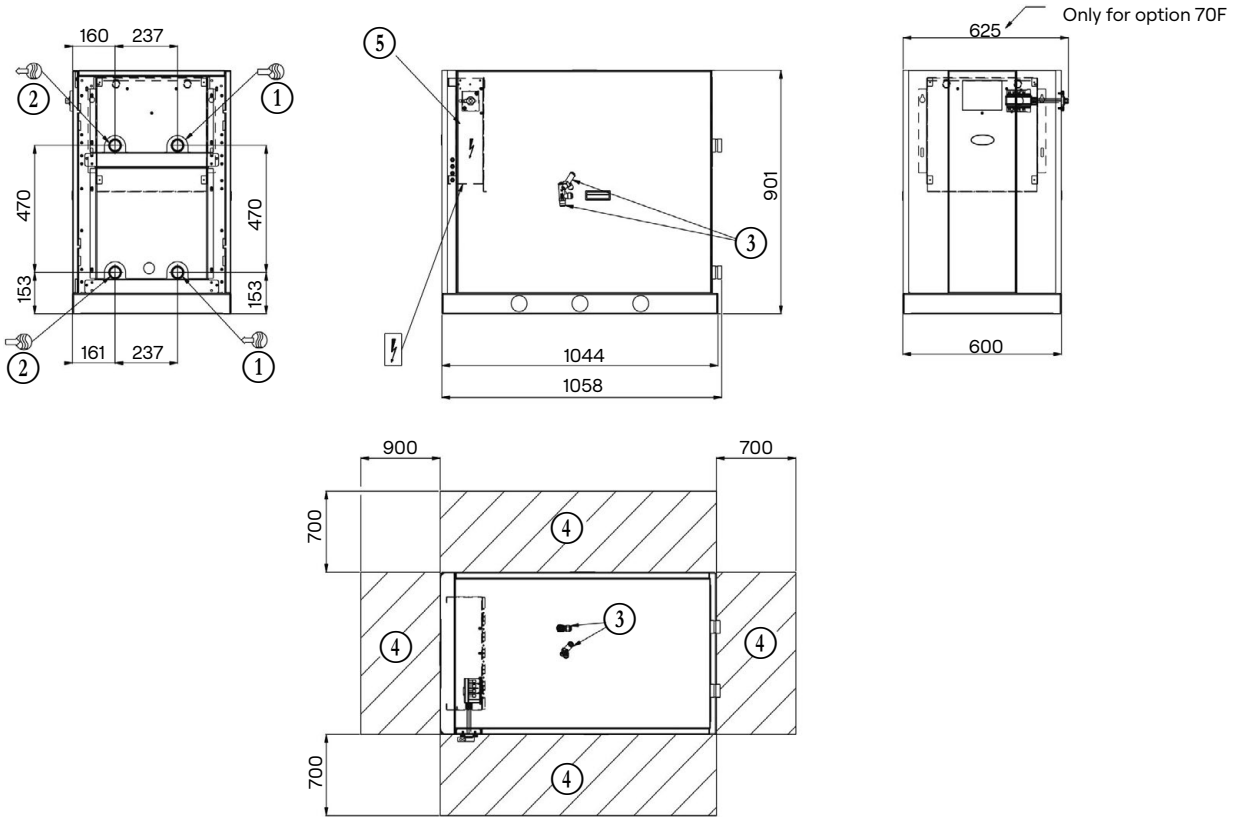

## 61WG/30WG 020-045 - unit with top connections (option 274)

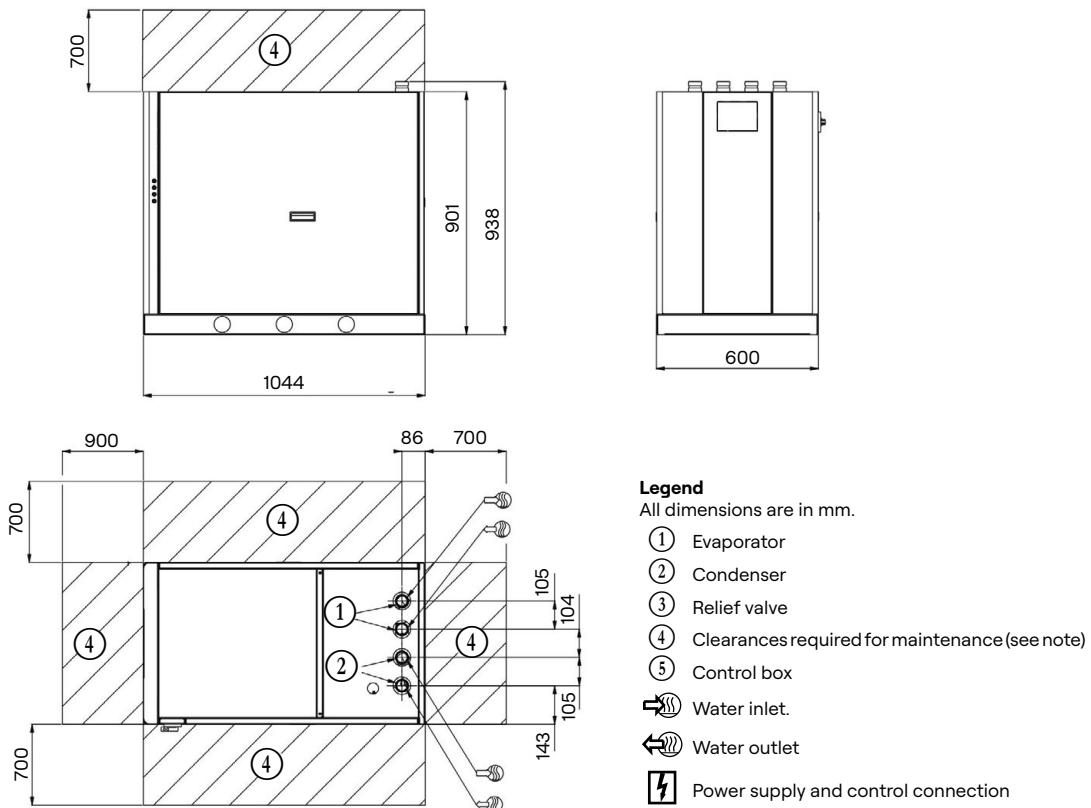

**NOTE: Non-contractual drawings. Refer to the certified dimensional drawings available on request, when designing an installation.**

## Dimensions/clearances

### 61WG/30WG 020-045 - unit with evaporator hydraulic module (option 116)

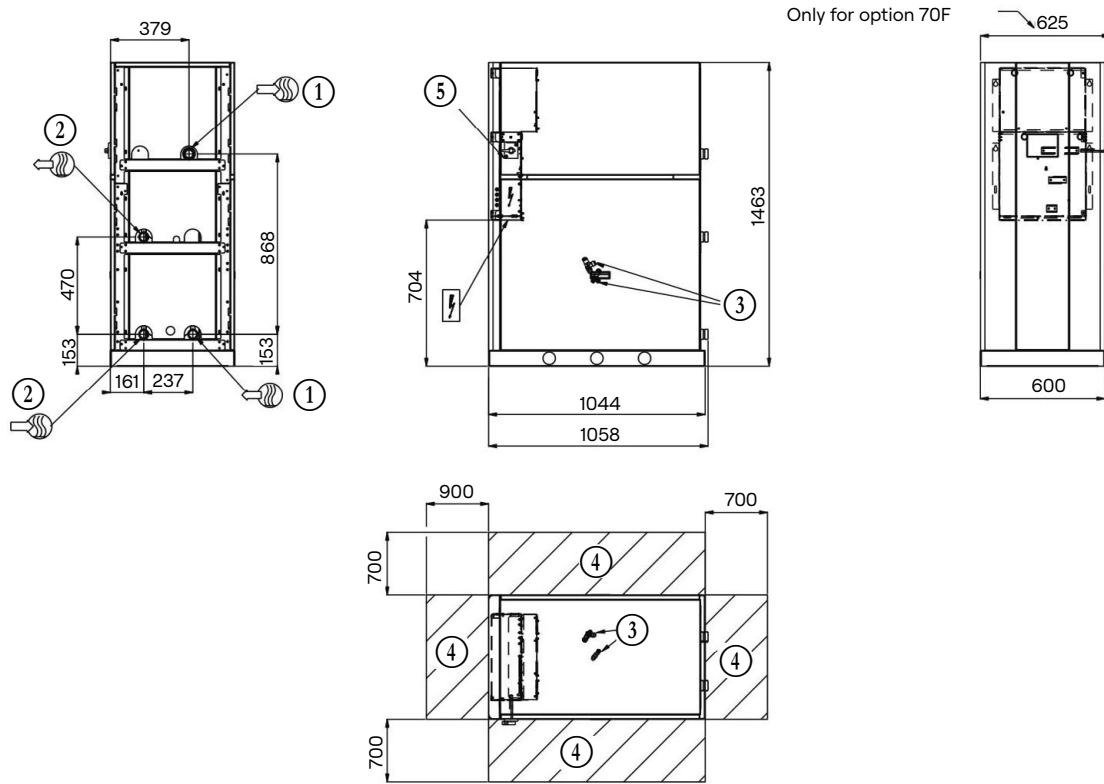

### 61WG/30WG 020-045 - unit with condenser hydraulic module (option 270)

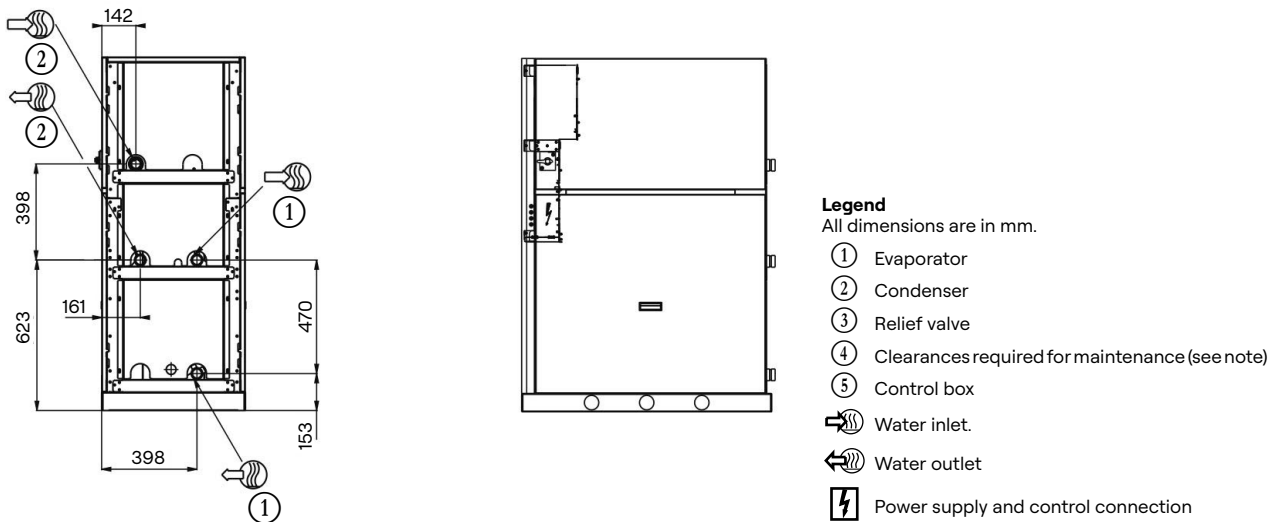

**NOTE: Non-contractual drawings. Refer to the certified dimensional drawings available on request, when designing an installation.**

## Dimensions/clearances

### 61WG/30WG 020-045 - unit with evaporator/condenser hydraulic modules (options 116 + 270)

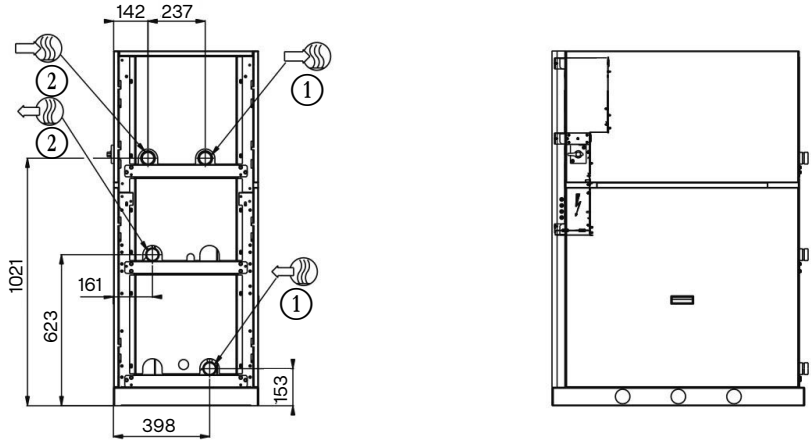

### 61WG/30WG 020-045 - unit with hydraulic module and top connections (options 116 + 274 or 270 + 274 or 116 + 270 + 274)

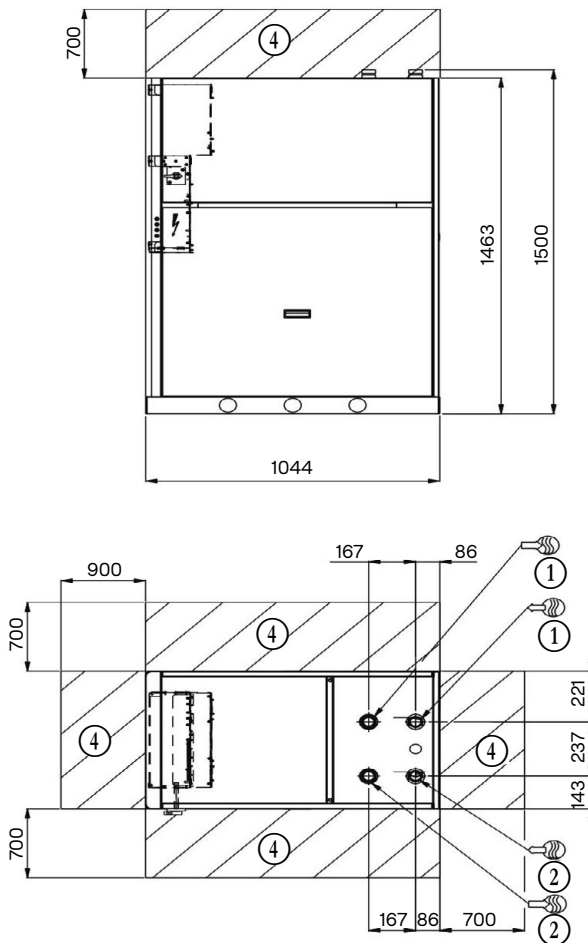

**Legend**

All dimensions are in mm.

- ① Evaporator
- ② Condenser
- ③ Relief valve
- ④ Clearances required for maintenance (see note)
- ⑤ Control box
- ➔ Water inlet.
- ➔ Water outlet
- ⚡ Power supply and control connection

**NOTE: Non-contractual drawings. Refer to the certified dimensional drawings available on request, when designing an installation.**

## Dimensions/clearances

### 61WG/30WG 020-045 - stackable unit (option 273)

**NOTE:** The water and electrical connections are identical to those of the standard unit.

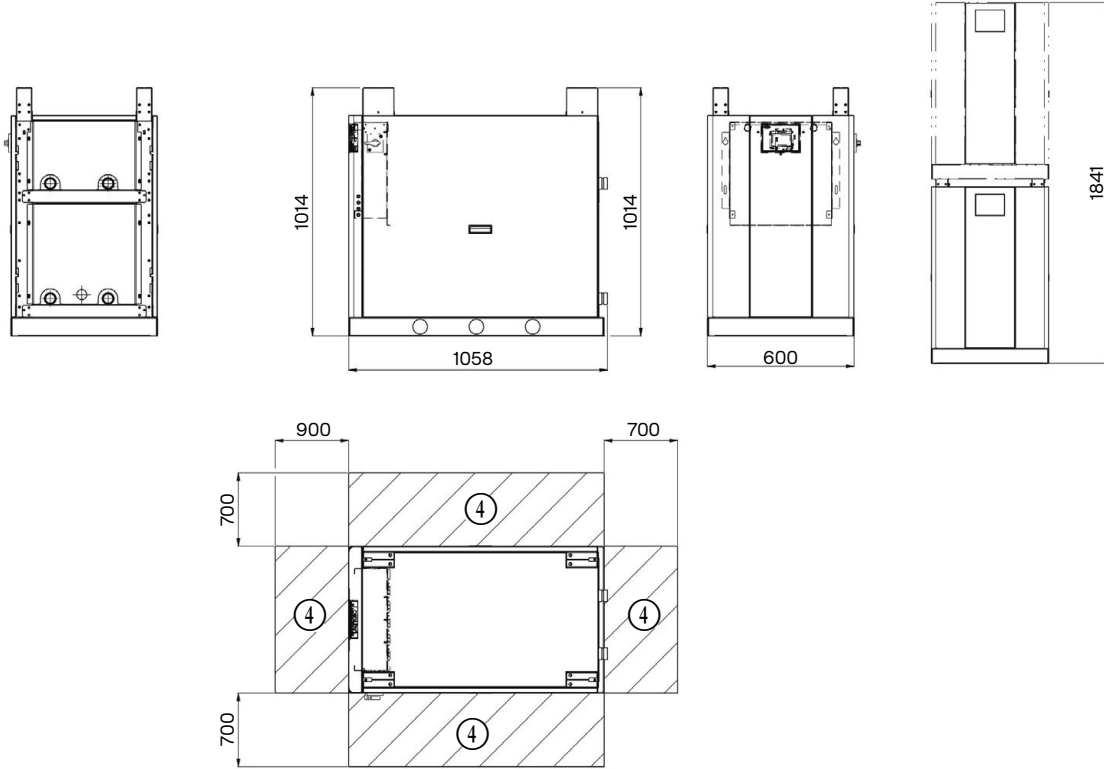

### 61WG/30WG 050-090 - standard unit

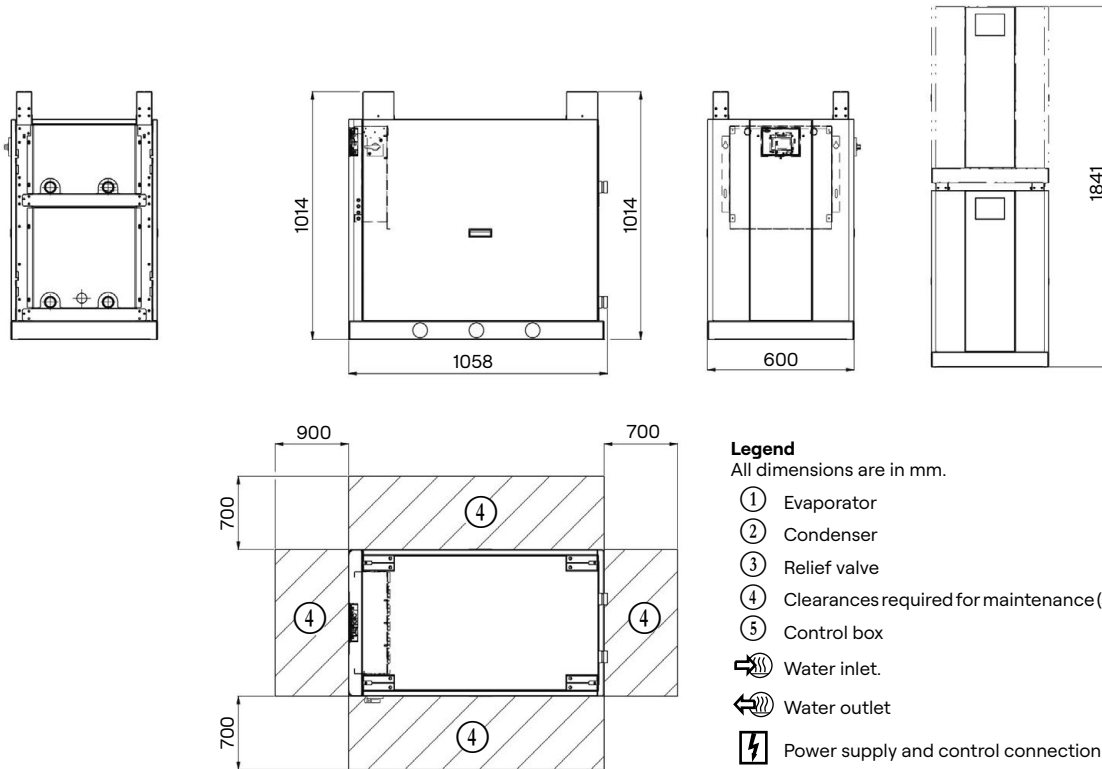

**NOTE:** Non-contractual drawings. Refer to the certified dimensional drawings available on request, when designing an installation.

## Dimensions/clearances

### 61WG/30WG 050-090 - unit with top connections (option 274)

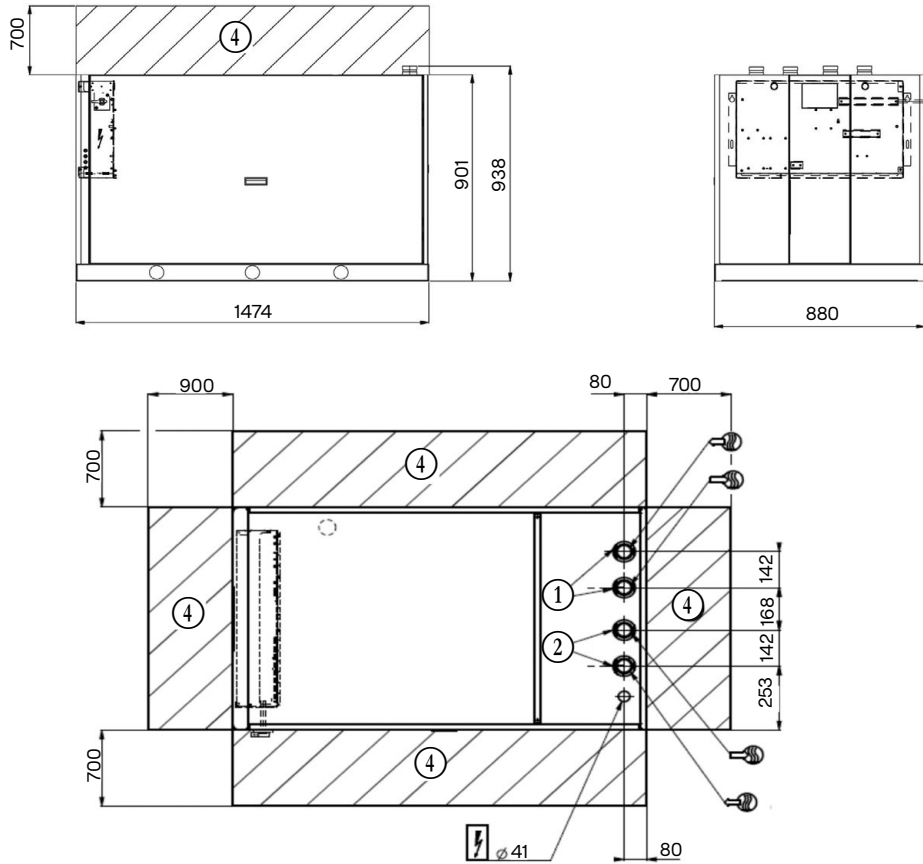

### 61WG/30WG 050-090 - unit with evaporator hydraulic module (option 116)

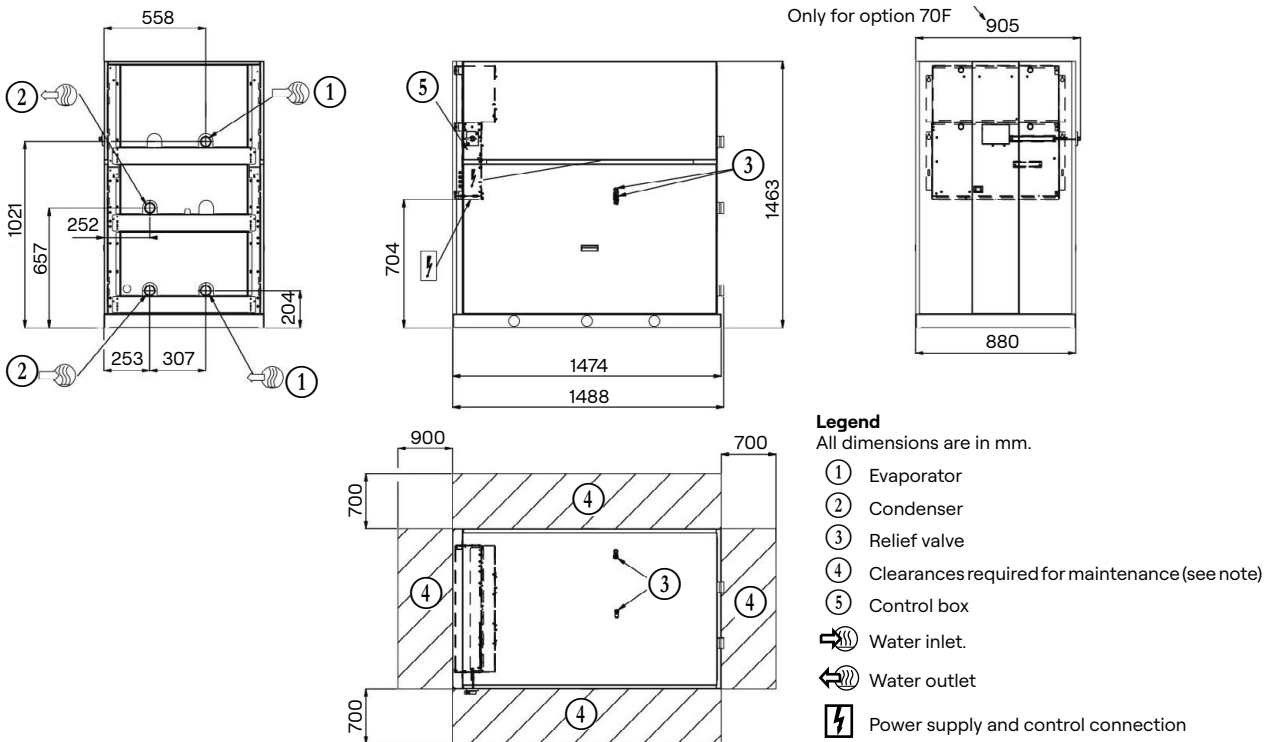

**NOTE: Non-contractual drawings. Refer to the certified dimensional drawings available on request, when designing an installation.**

## Dimensions/clearances

### 61WG/30WG 050-090 - unit with condenser hydraulic module (option 270)

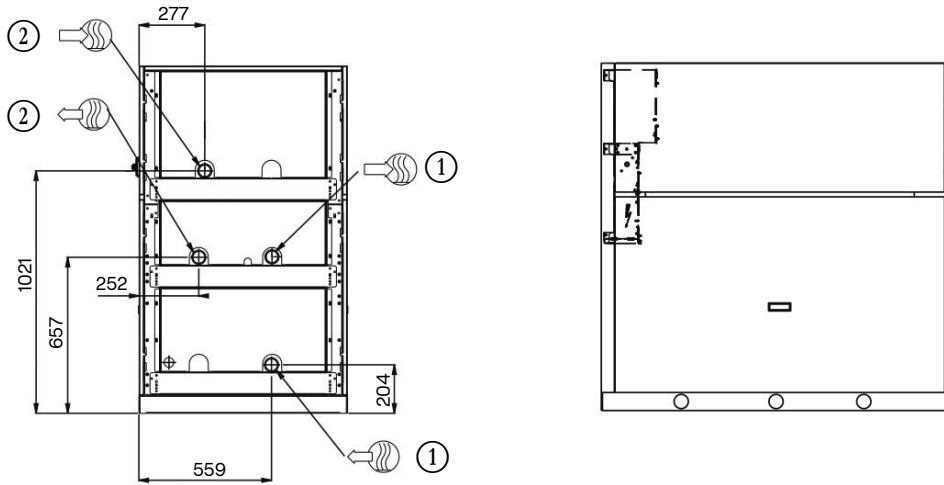

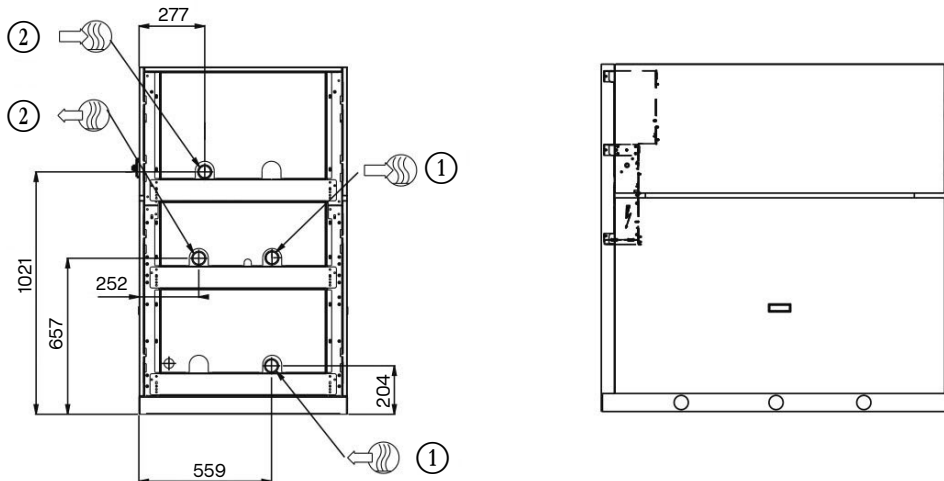

### 61WG/30WG 050-090 - unit with evaporator/condenser hydraulic modules (options 116 + 270)



**Legend**

All dimensions are in mm.

- ① Evaporator
- ② Condenser
- ③ Relief valve
- ④ Clearances required for maintenance (see note)
- ⑤ Control box
-  Water inlet.
-  Water outlet
-  Power supply and control connection

**NOTE: Non-contractual drawings. Refer to the certified dimensional drawings available on request, when designing an installation.**

## Dimensions/clearances

### 61WG/30WG 050-090 - unit with hydraulic module and top connections (options 116 + 274 or 270 + 274 or 116 + 270 + 274)

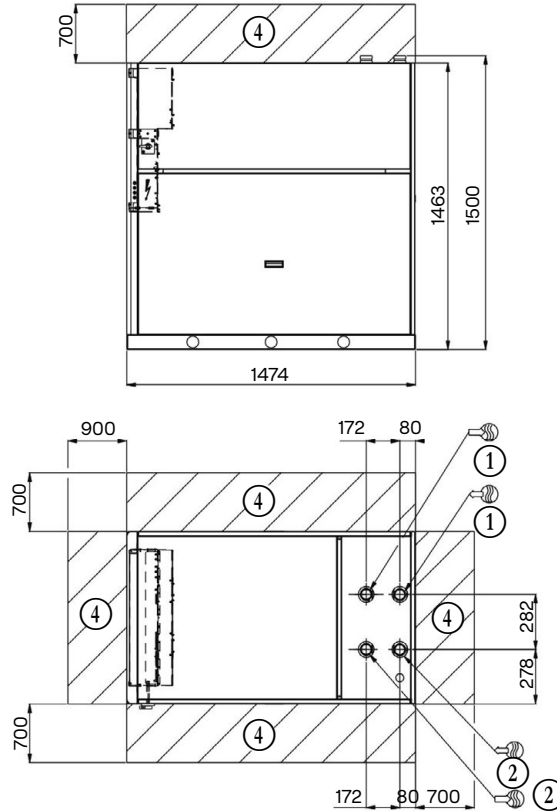

### 61WG/30WG 050-090 - stackable unit (option 273)

NOTE: The water and electrical connections are identical to those of the standard unit.

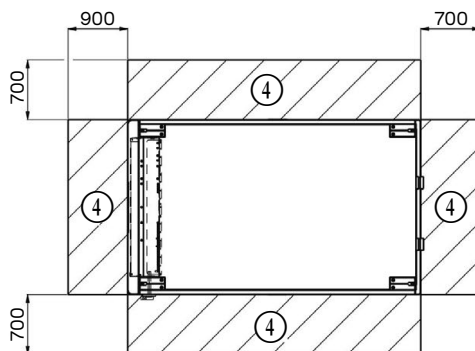
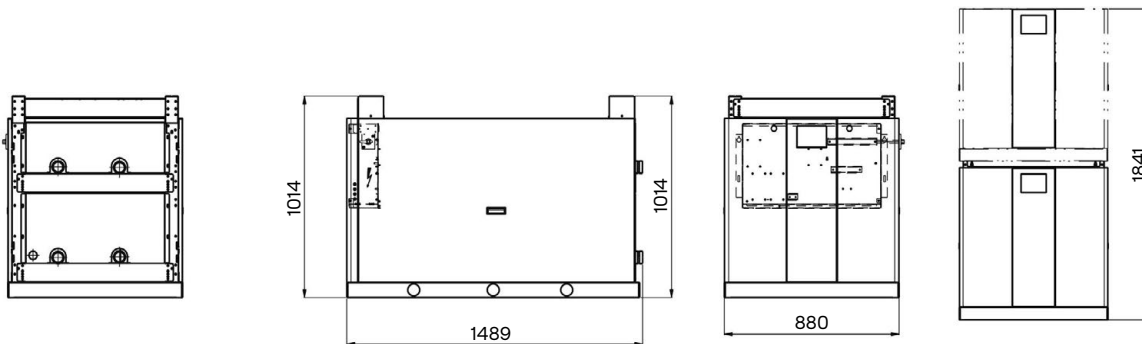

**Legend**

All dimensions are in mm.

- ① Evaporator
- ② Condenser
- ③ Relief valve
- ④ Clearances required for maintenance (see note)
- ⑤ Control box
- Water inlet.
- Water outlet
- Power supply and control connection

NOTE: Non-contractual drawings. Refer to the certified dimensional drawings available on request, when designing an installation.

## Dimensions/clearances

### 30WG 110-140 - standard unit

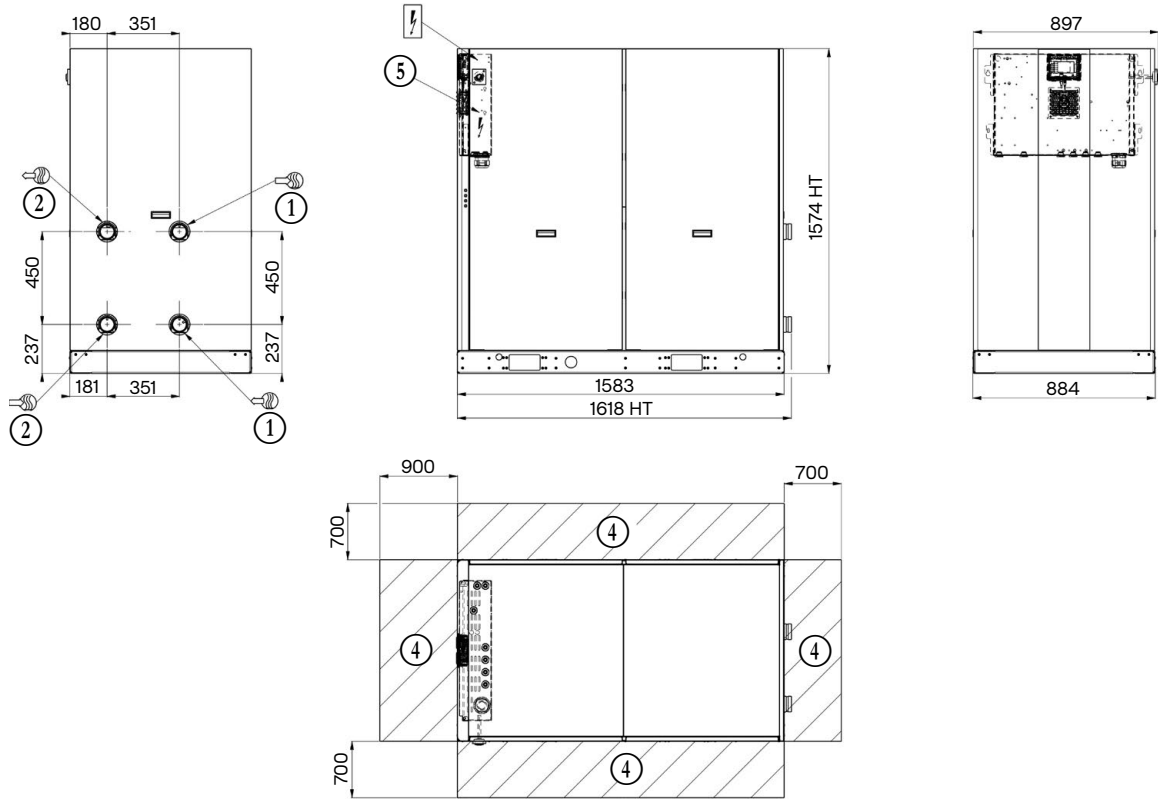

### 30WG 110-140 - unit with top connections (option 274)

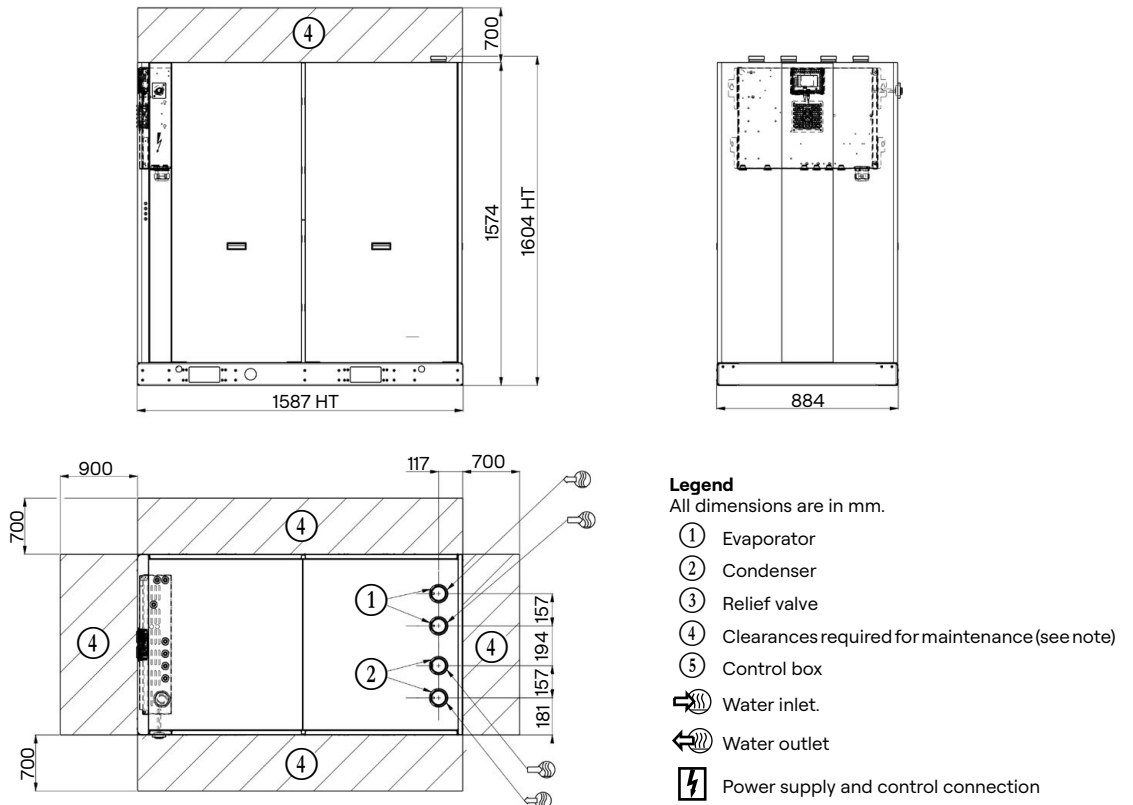

**NOTE: Non-contractual drawings. Refer to the certified dimensional drawings available on request, when designing an installation.**

# Dimensions/clearances

## 30WG 150-190 - standard unit

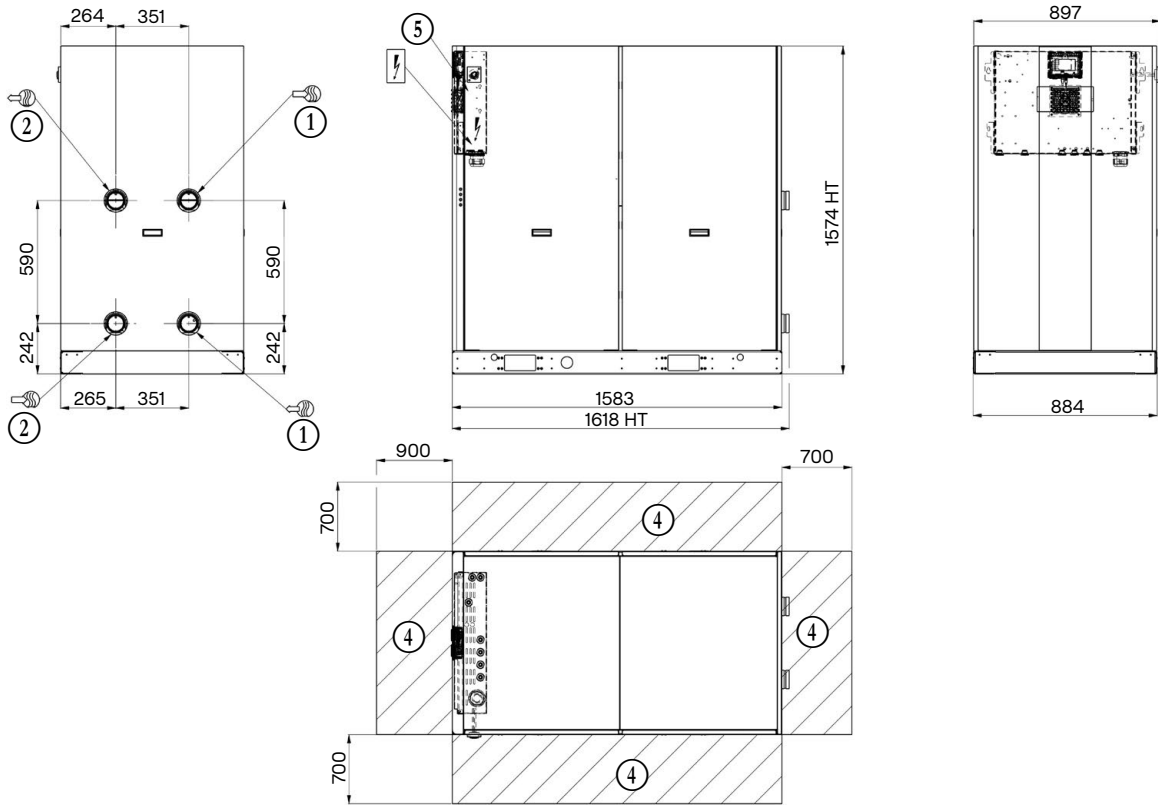

## 30WG 150-190 - unit with top connections (option 274)

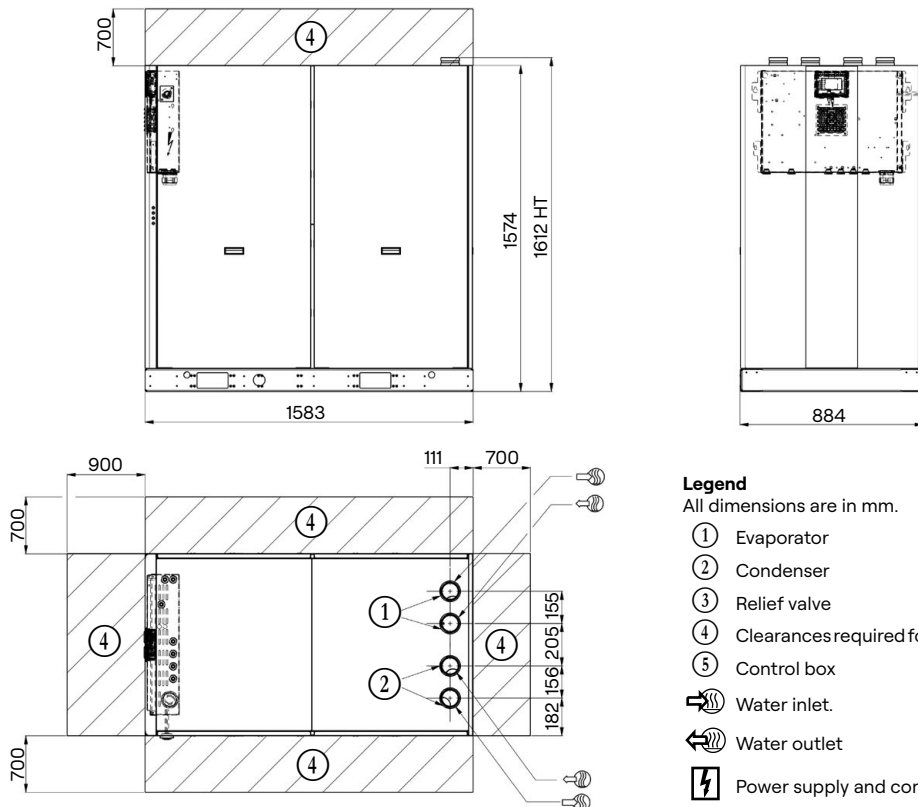

**NOTE: Non-contractual drawings. Refer to the certified dimensional drawings available on request, when designing an installation.**

## Dimensions/clearances

### 30WG 110-140 - unit with hydraulic module (option 116-270)

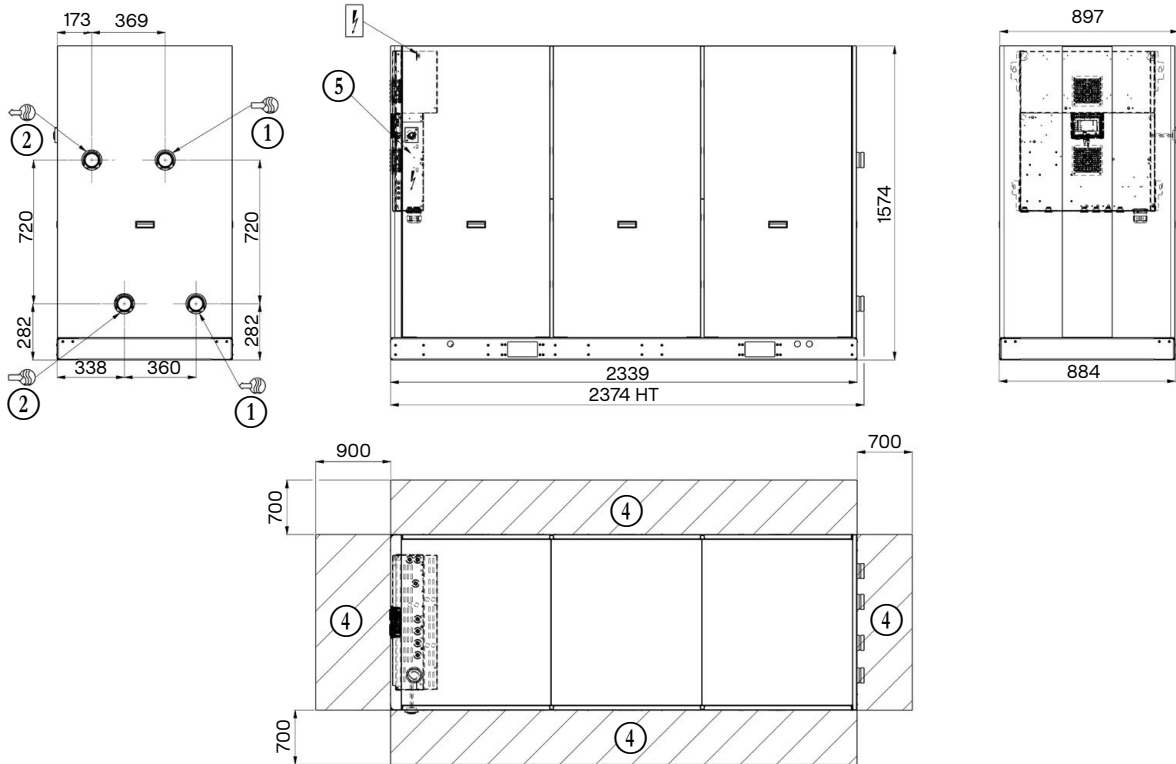

### 30WG 110-140 - unit with hydraulic module and top connections (option 116-270 and 274)

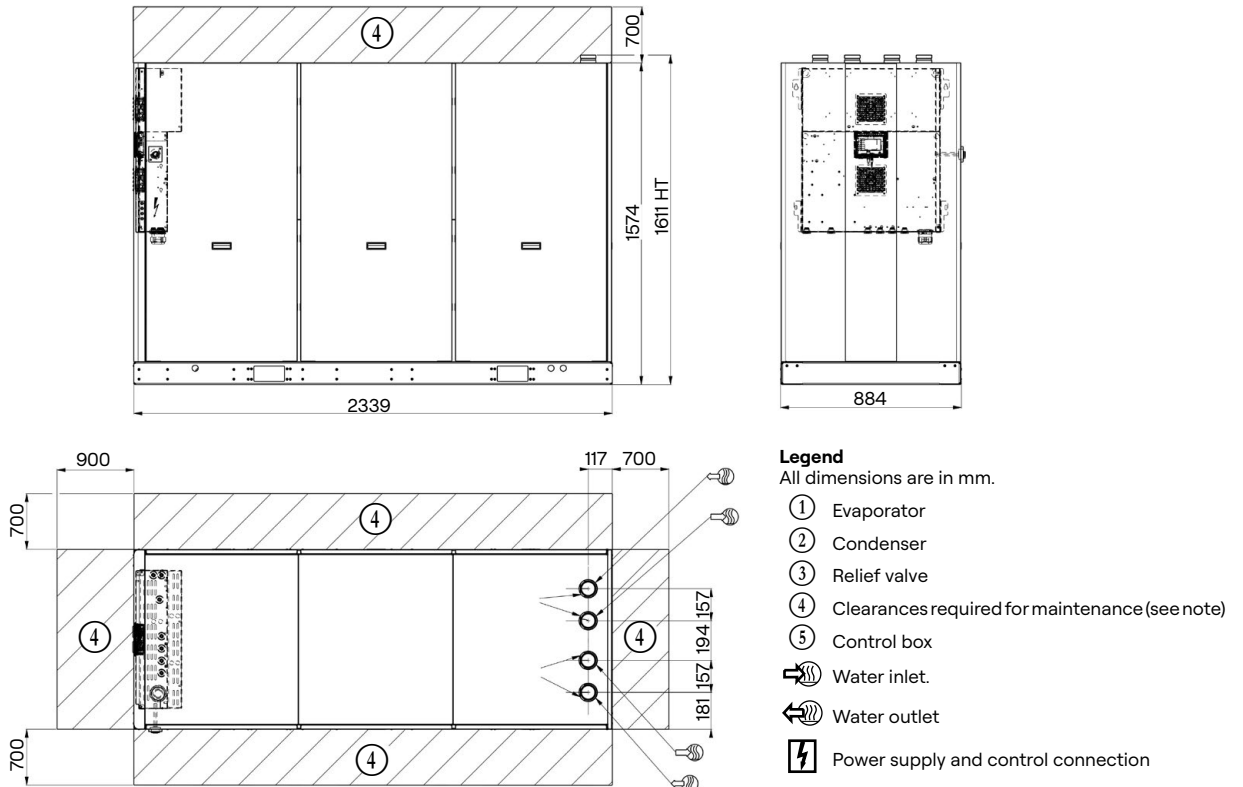

**NOTE: Non-contractual drawings. Refer to the certified dimensional drawings available on request, when designing an installation.**

## Dimensions/clearances

### 30WG 150-190 - unit with hydraulic module (option 116-270)

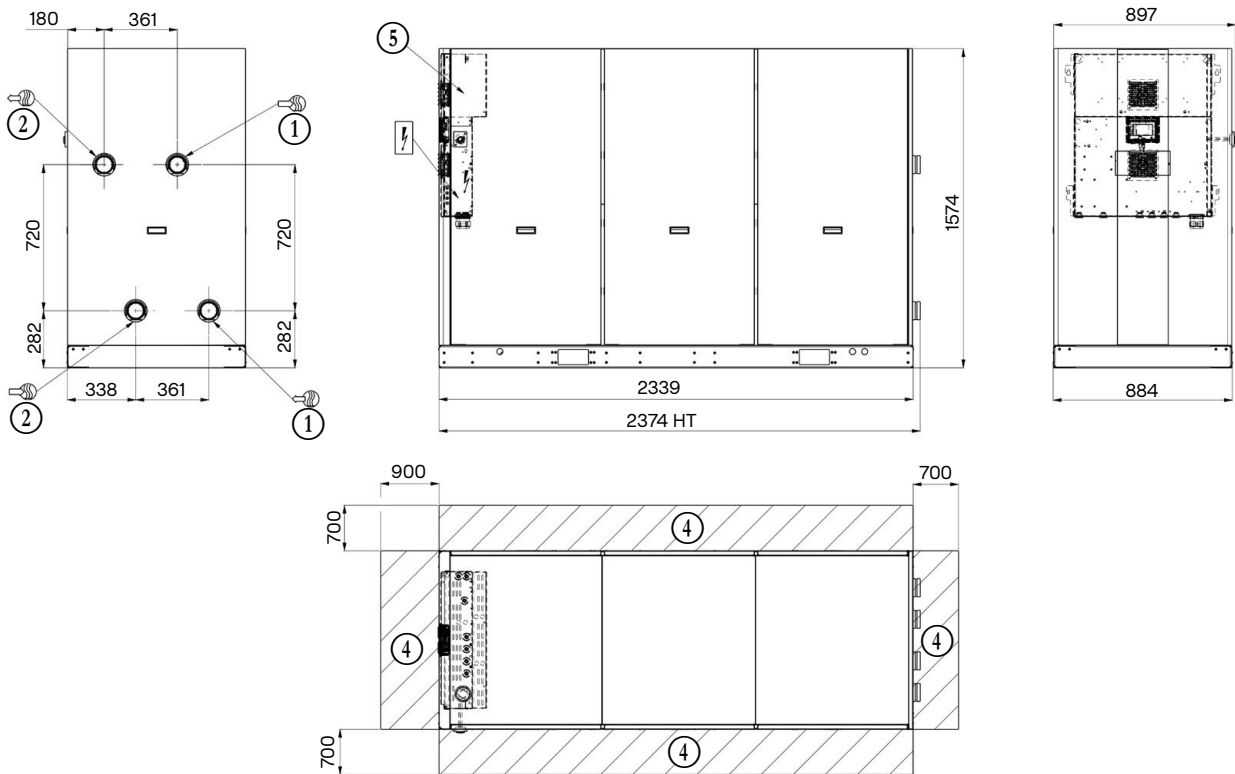

### 30WG 150-190 - unit with hydraulic module and top connections (option 116-270 and 274)

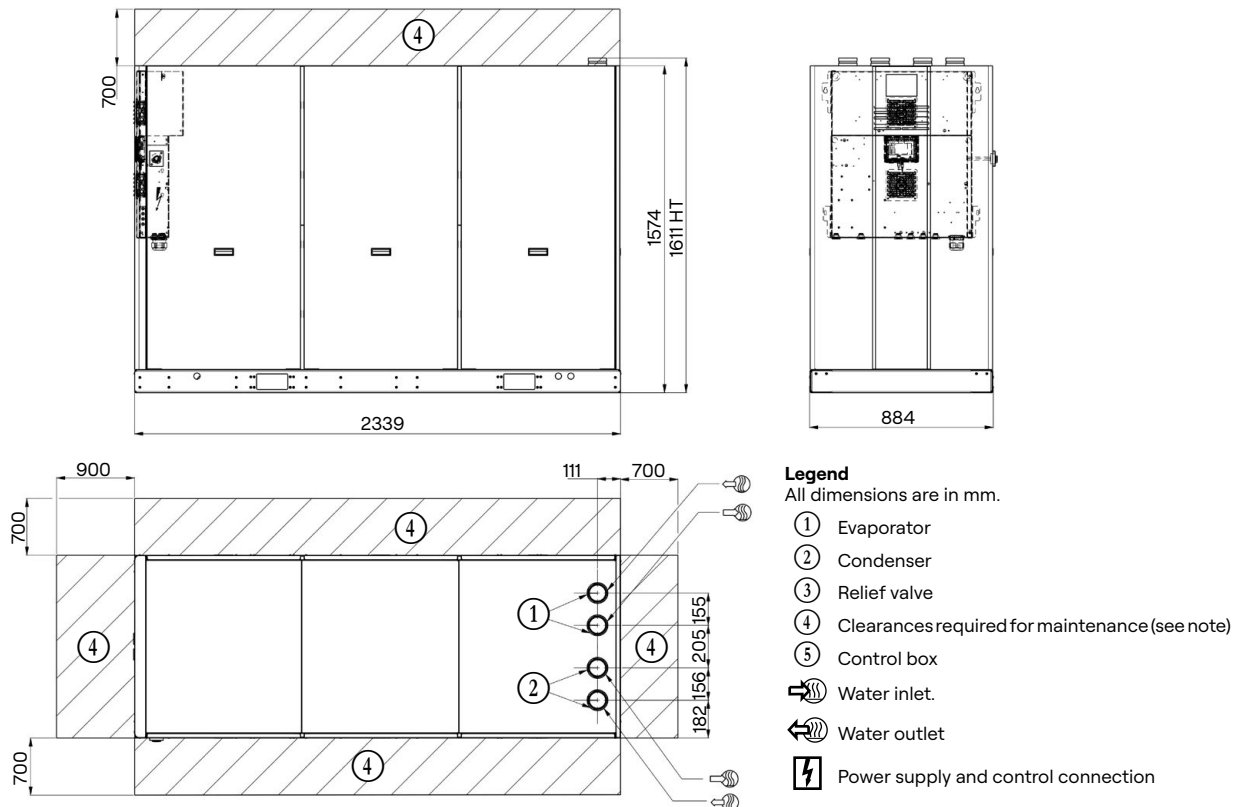

**NOTE: Non-contractual drawings. Refer to the certified dimensional drawings available on request, when designing an installation.**